

# 多级离心泵

## Multistage centrifugal pump



**辰禹（重庆）流体设备有限公司**

**Chenyu(chongqing) fluid equipment co., LTD**

# 目录Catalogue

一、概述 Summary .....	1
二、产品特点: Product technical features .....	1
三、使用参数范围 using the range of parameter .....	1
四、过流部件材质代号 Flow component material code .....	2
五、型号意义 Model significance .....	2
六、泵性能曲线图 Performmance curve chart .....	3
七、性能参数表 Performance parameter list .....	6
八、外形尺寸安装图 Outline dimension mounting chart .....	16
九、外形安装尺寸表 Outline installation dimension table .....	17

# 一、概述 Summary

**多级离心泵** 是我公司生产的节能环保型产品。适合农村、城市生产生活取水；煤矿矿山给水和排水；石油、化工、煤加工、铝加工、造纸、制糖、供水、供暖、空调、发电、环保、清洗、消防等行业输送清水、热水，也可以输送腐蚀液体或含有泥沙等固体颗粒浓度小于 15%液体。

Multi-stage centrifugal pump is an energy-saving and environmentally friendly product produced by our company. It is suitable for taking water for production and living in rural and urban areas; water supply and drainage for coal mines; water and hot water for petroleum, chemical, coal processing, aluminum processing, papermaking, sugar, water supply, heating, air conditioning, power generation, environmental protection, cleaning, fire fighting and other industries, It can also transport corrosive liquids or liquids that contain solid particles such as silt and whose concentration is less than 15%.

## 二、产品特点： Product technical features

**节 电**：可节约 3-12%的电能。

**更 耐 用**：没有交变应力，也没接触磨损，大大提高了泵的耐用性，很少维修，运行成本低。

**检修快捷**：设计的联轴器，检修时快速、省时。

**环 保**：采用的材料，没有二次污染。

Power saving: power can save 3-12 percent.

More resistant to: no alternating stress, no contact wear, greatly improving the durability of the pump, very little maintenance, running low cost.

Maintenance shortcut: Design of the coupling, quick, time saving.

Environment protection: The material will not cause re-pollution.

## 三、使用参数范围 using the range of parameter

口径 caliberDN: 40-800mm;

流量 The flow of Q: 3~ 4980m<sup>3</sup>/h;

压力 The maximum pressure H: 最大 13MPa;

工作温度 Working temperatureT: -80℃ ~+250℃

## 四、过流部件材质代号 Flow component material code

材料类别 Material category	I	II (ZG35)	III (304)
材质 material quality	HT250	碳钢 Carbon steel	ZG0Cr17Ni9
材料类别 Material category	IV (304L)	V (316)	VI (316L)
材质 material quality	ZG00Cr19Ni11	ZG0Cr18Ni12M02Ti	ZG00Cr17Ni14M02

## 五、型号意义 Model significance

D 6 - 25 × 6

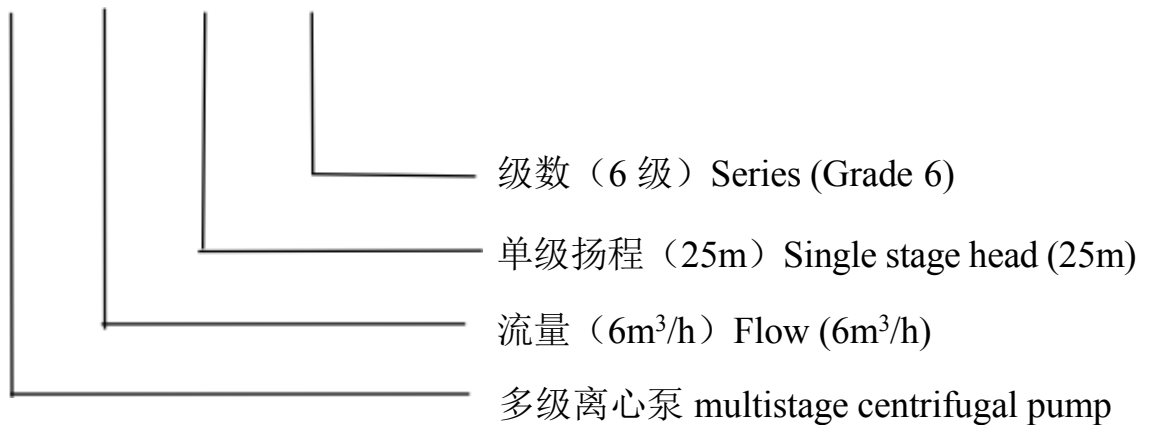

# 六、泵性能曲线图 Performance curve chart

性能曲线图

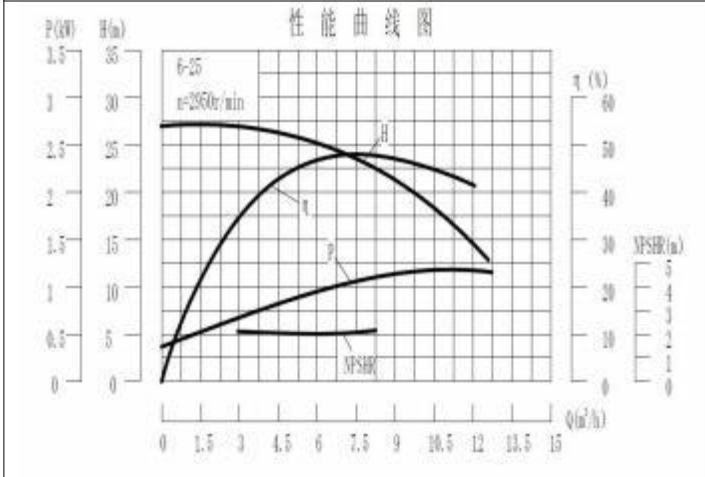

D6-25 泵技术数据 Technical Data

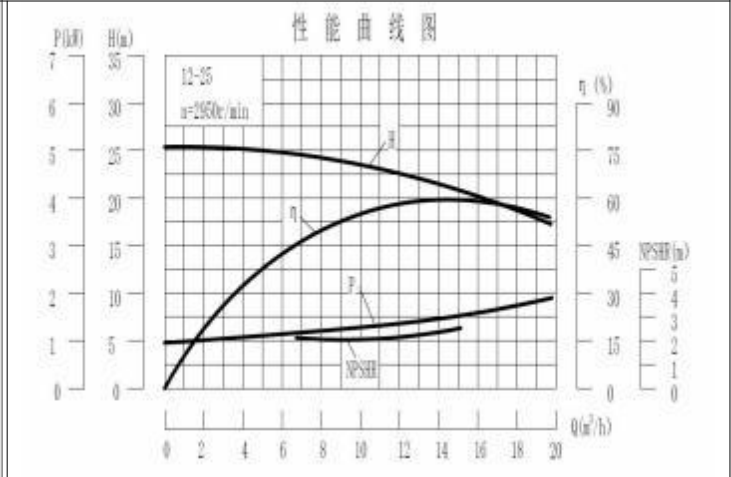

D12-25 泵技术数据 Technical Data

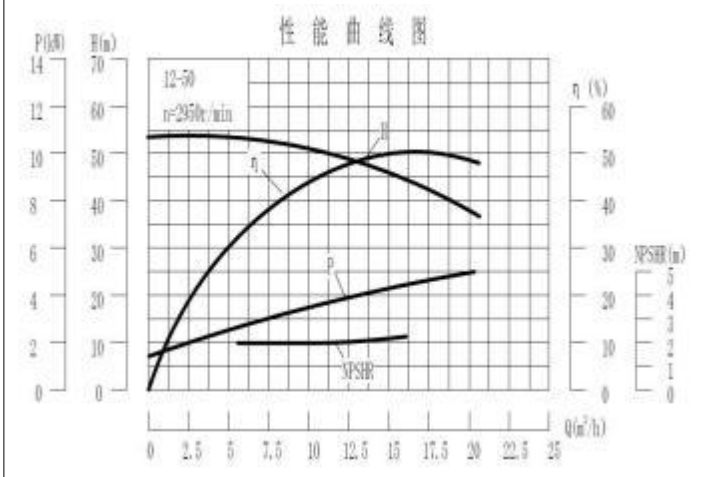

D12-50 泵技术数据 Technical Data

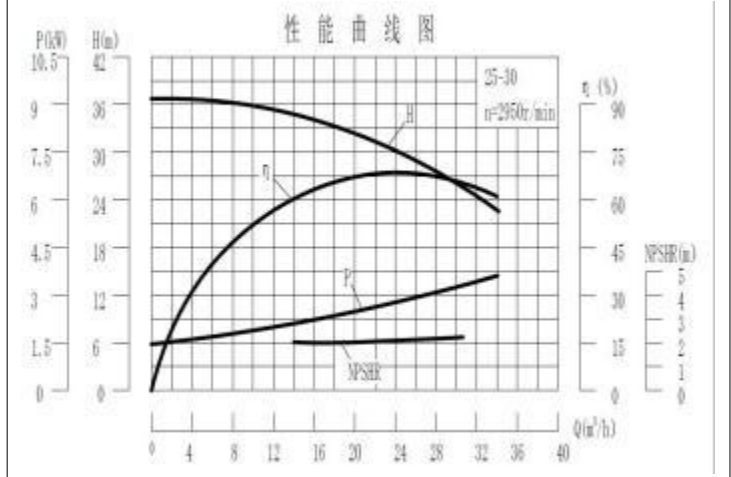

D25-30 泵技术数据 Technical Data

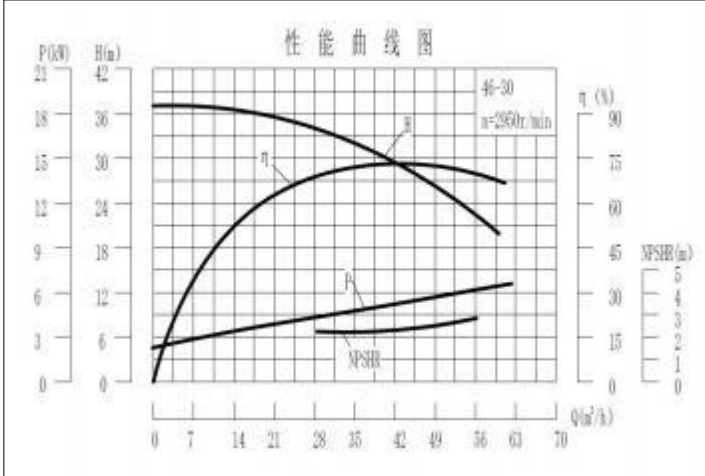

D46-30 泵技术数据 Technical Data

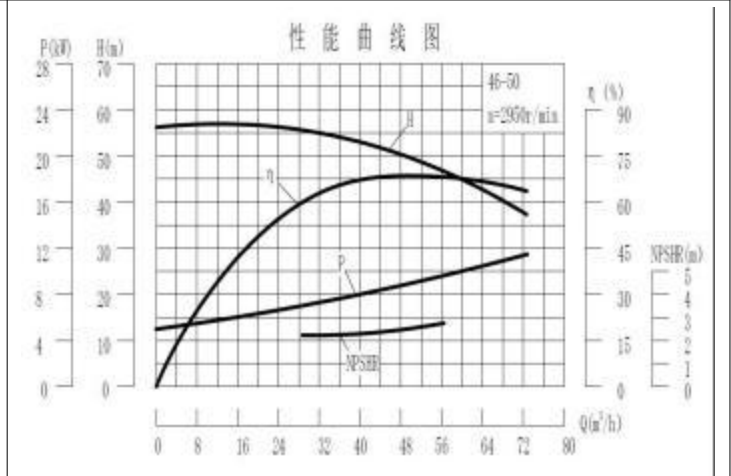

D46-50 泵技术数据 Technical Data

## 性能曲线图 Performance curve diagram

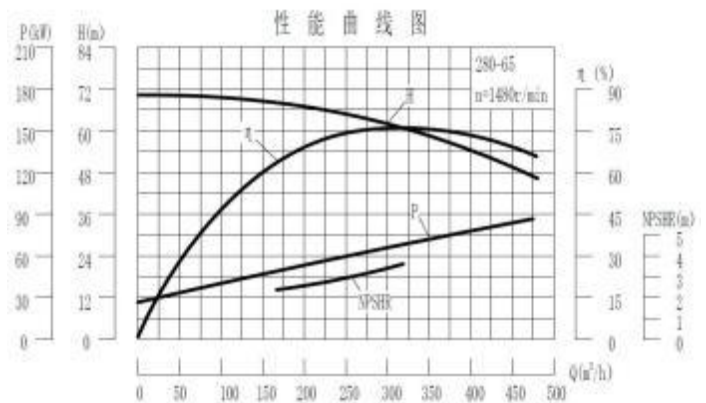
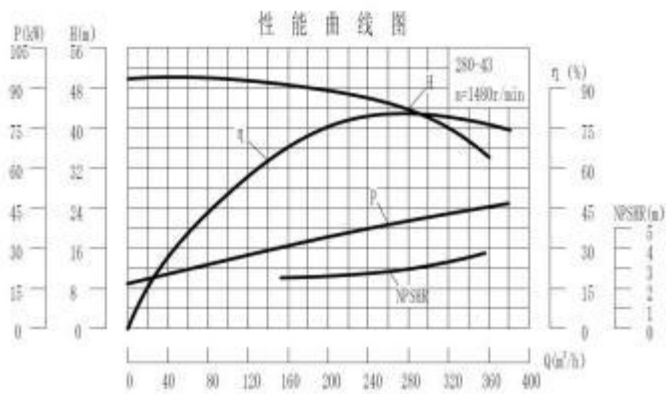
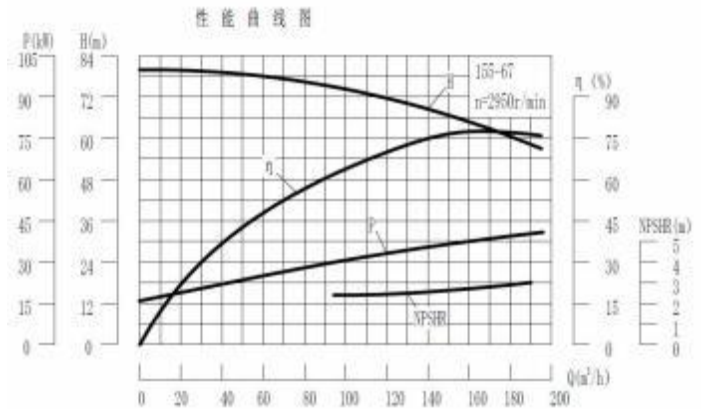
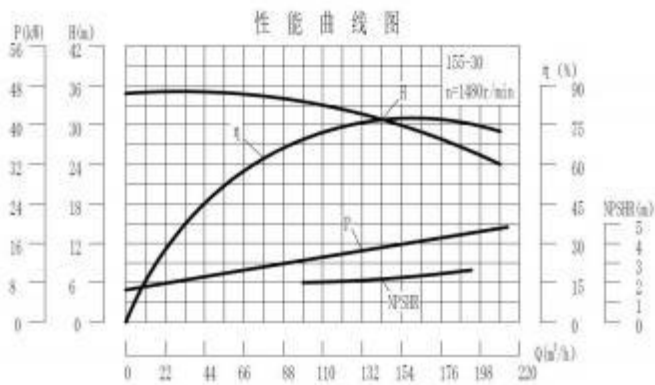
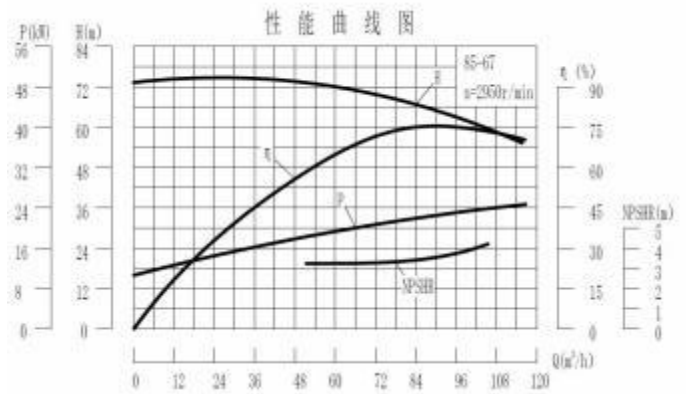
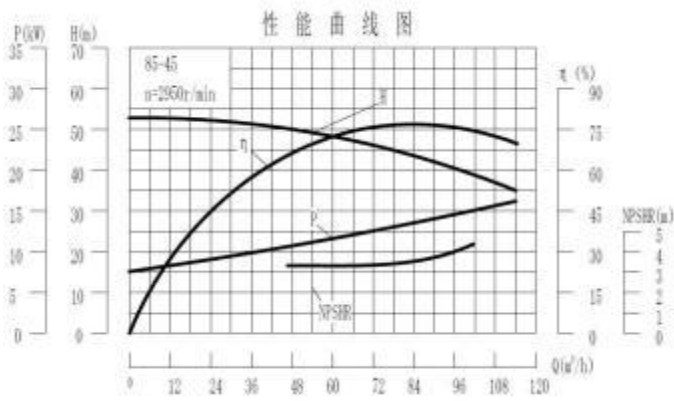

## 性能曲线图 Performance curve diagram

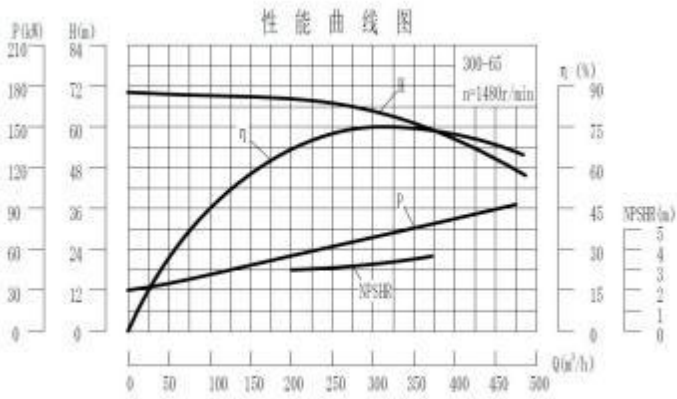

D300-65 泵技术数据 Technical Data

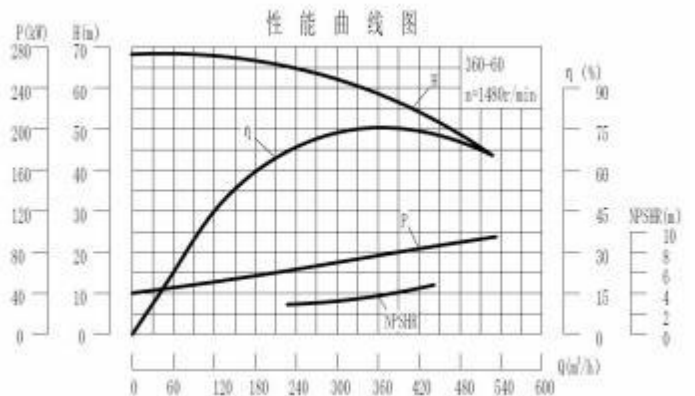

D360-60 泵技术数据 Technical Data

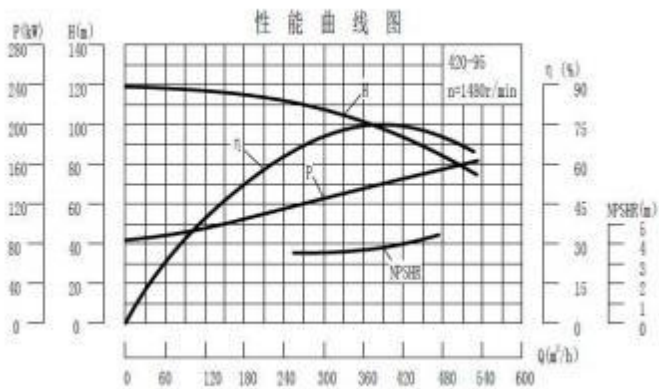

D420-95 泵技术数据 Technical Data

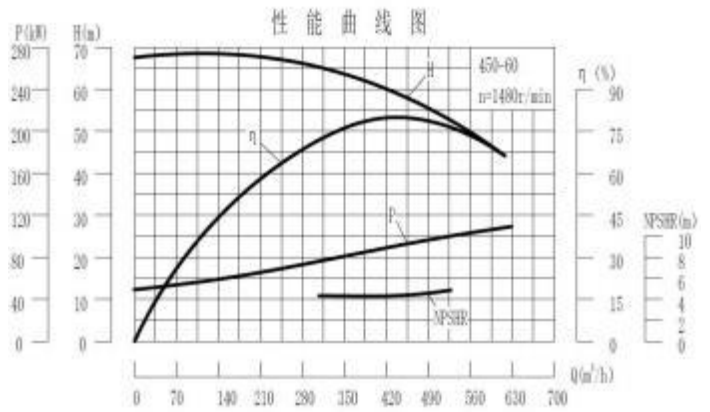

D460-60 泵技术数据 Technical Data

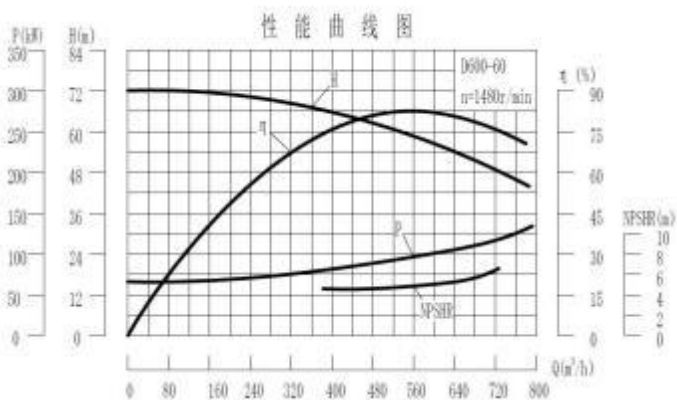

D600-60 泵技术数据 Technical Data

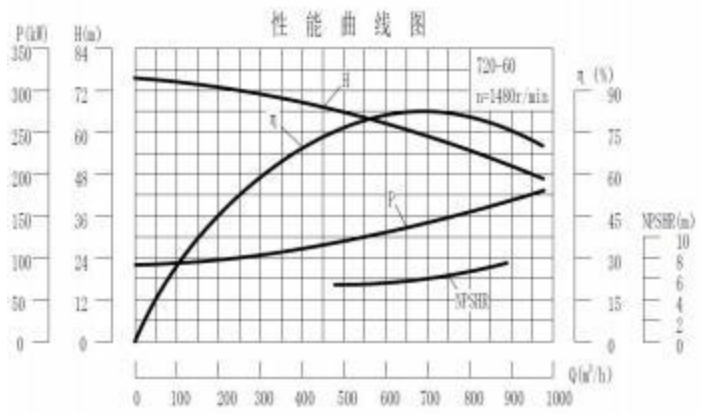

D720-60 泵技术数据 Technical Data

# 七、性能参数表 Performance parameter list

性能参数表 Performance parameter list															
型号	转速 n (r/min)	流量 Q (m³/h)	扬程 H (m)	效率 η (%)	功率 (kW)		气蚀余量 (NPSH)r (m)	型号	转速 n (r/min)	流量 Q (m³/h)	扬程 H (m)	效率 η (%)	功率 (kW)		气蚀余量 (NPSH) r (m)
					轴功率	电机功率							轴功率	电机功率	
6-25×3	2950	3.75	76.5	38	2.06	4	2.0	12-25×13	2950	7.5	366.6	49	15.28	30	2.0
		6.3	75	50	2.57		2.0			12.5	325	59	18.74		2.0
		7.5	73.5	52	2.89		2.5			15.0	299	58	21.05		2.5
6-25×4	2950	3.75	102	38	2.74	5.5	2.0	12-25×14	2950	7.5	394.8	49	16.45	30	2.0
		6.3	100	50	3.43		2.0			12.5	350	59	20.19		2.0
		7.5	98	52	3.85		2.5			15.0	322	58	22.67		2.5
6-25×5	2950	3.75	127.5	38	3.43	7.5	2.0	12-50×3	2950	6.3	158.8	36	7.57	15	2.2
		6.3	125	50	4.29		2.0			12.5	150	48	10.64		2.5
		7.5	122.5	52	4.81		2.5			15.0	142.7	50	11.65		2.8
6-25×6	2950	3.75	153	38	4.11	7.5	2.0	12-50×4	2950	6.3	211.7	36	10.09	22	2.2
		6.3	150	50	5.15		2.0			12.5	200	48	14.18		2.5
		7.5	147	52	5.78		2.5			15.0	190.3	50	15.54		2.8
6-25×7	2950	3.75	178.5	38	4.80	11	2.0	12-50×5	2950	6.3	264.6	36	12.61	30	2.2
		6.3	175	50	6.00		2.0			12.5	250	48	17.72		2.5
		7.5	171.5	52	6.73		2.5			15.0	237.9	50	19.43		2.8
6-25×8	2950	3.75	204	38	5.48	11	2.0	12-50×6	2950	6.3	317.5	36	15.13	30	2.2
		6.3	200	50	6.86		2.0			12.5	300	48	21.27		2.5
		7.5	196	52	7.70		2.5			15.0	285.5	50	23.32		2.8
6-25×9	2950	3.75	229.5	38	6.17	11	2.0	12-50×7	2950	6.3	370.4	36	17.65	37	2.2
		6.3	225	50	7.72		2.0			12.5	350	48	24.81		2.5
		7.5	220.5	52	8.66		2.5			15.0	333.1	50	27.20		2.8
6-25×10	2950	3.75	255	38	6.85	15	2.0	12-50×8	2950	6.3	423.4	36	20.17	37	2.2
		6.3	250	50	8.58		2.0			12.5	400	48	28.36		2.5
		7.5	245	52	9.62		2.5			15.0	380.6	50	31.08		2.8
6-25×11	2950	3.75	280.5	38	7.54	15	2.0	12-50×9	2950	6.3	476.3	36	22.69	45	2.2
		6.3	275	50	9.43		2.0			12.5	450	48	31.90		2.5
		7.5	269.5	52	10.58		2.5			15.0	428.2	50	34.97		2.8
6-25×12	2950	3.75	306	38	8.22	18.5	2.0	12-50×10	2950	6.3	529.2	36	25.21	55	2.2
		6.3	300	50	10.29		2.0			12.5	500	48	35.45		2.5
		7.5	294	52	11.54		2.5			15.0	475.8	50	38.86		2.8
6-25×13	2950	3.75	331.5	38	8.91	18.5	2.0	12-50×11	2950	6.3	582.1	36	27.73	55	2.2
		6.3	325	50	11.15		2.0			12.5	550	48	39.00		2.5
		7.5	318.5	52	12.51		2.5			15.0	523.4	50	42.74		2.8
6-25×14	2950	3.75	357	38	9.59	18.5	2.0	12-50×12	2950	6.3	635	36	30.25	55	2.2
		6.3	350	50	12.00		2.0			12.5	600	48	42.53		2.5
		7.5	343	52	13.47		2.5			15.0	571	50	46.63		2.8
12-25×3	2950	7.5	84.6	49	3.53	5.5	2.0	25-30×3	2950	15	104.7	60	7.13	15	2.2
		12.5	75	59	4.33		2.0			25	90	66	9.28		2.2
		15.0	69	58	4.86		2.5			30	77.7	63	10.07		2.6
12-25×4	2950	7.5	112.8	49	4.7	11	2.0	25-30×4	2950	15	139.6	60	9.5	18.5	2.2
		12.5	100	59	5.77		2.0			25	120	66	12.37		2.2
		15.0	92	58	6.48		2.5			30	103.6	63	13.43		2.6
12-25×5	2950	7.5	141	49	5.88	11	2.0	25-30×5	2950	15	174.5	60	11.88	22	2.2
		12.5	125	59	7.21		2.0			25	150	66	15.47		2.2
		15.0	115	58	8.10		2.5			30	129.5	63	16.78		2.6
12-25×6	2950	7.5	179.2	49	7.47	15	2.0	25-30×6	2950	15	209.4	60	14.25	30	2.2
		12.5	150	59	8.65		2.0			25	180	66	18.56		2.2
		15.0	138	58	9.72		2.5			30	155.4	63	20.14		2.6
12-25×7	2950	7.5	197.4	49	8.23	15	2.0	25-30×7	2950	15	244.3	60	16.63	30	2.2
		12.5	175	59	10.101		2.0			25	210	66	21.65		2.2
		15.0	161	58	1.33		2.5			30	181.3	63	23.50		2.6
12-25×8	2950	7.5	225.6	49	9.4	15	2.0	25-30×8	2950	15	279.2	60	19.00	30	2.2
		12.5	200	59	11.53		2.0			25	240	66	24.75		2.2
		15.0	184	58	12.95		2.5			30	207.2	63	26.86		2.6
12-25×9	2950	7.5	253.8	49	10.58	18.5	2.0	25-30×9	2950	15	314.1	60	21.38	37	2.2
		12.5	225	59	12.98		2.0			25	270	66	27.84		2.2
		15.0	207	58	14.57		2.5			30	233.1	63	30.22		2.6

## 性能参数表 Performance parameter list

型 号	转速 n (r/min)	流量 Q (m³/h)	扬程 H (m)	效率 η (%)	功率 (kW)		气蚀余量 (NPSH)r (m)	型 号	转速 n (r/min)	流量 Q (m³/h)	扬程 H (m)	效率 η (%)	功率 (kW)		气蚀余量 (NPSH) r (m)														
					轴 功率	电机 功率							轴 功率	电机 功率															
12-25×10	7.5 12.5 15.0	282 250 230	49 59 58	11.751 1.42 16.19	18.5	2.0 2.0 2.5	25-30×10			15 25 30	349 300 259	60 66 63	23.75 30.93 33.57	37	2.2 2.2 2.6														
																7.5 12.5 15.0	310.2 275 253	49 59 58	12.931 5.86 17.82	22	2.0 2.0 2.5	25-50×2		15 25 30	112 100 91	50.5 57 55	9.1 12 13.5	15	2.7 3 3.4
15 25 30	224 200 182	50.5 57 55	18.1 24 27	30	2.7 3 3.4	46-30×10		30 46 55	340 300 270	68 74 72	40.8 3 50.7 7 56.1 5	75	2.4 3.0 4.6																
														15 25 30	280 250 227.5	50.5 57 55	22.6 30 33.8	37	2.7 3 3.4	46-50×3		30 46 55	166.5 150 138	58 67 68	23.4 4 28.0 3 30.3 8	37	2.5 2.8 3.2		
																												15 25 30	336 300 273
15 25 30	392 350 318.5	50.5 57 55	31.7 42 41.3	45	2.7 3 3.4	46-50×5		30 46 55	277.5 250 230	58 67 68	39.0 7 46.7 2 50.6 4	55	2.5 2.8 3.2																
														15 25 30	448 400 364	50.5 57 55	36.2 48 54.1	55	2.7 3 3.4	46-50×6		30 46 55	330 300 276	58 67 68	46.4 7 56.0 7 60.7 7	75	2.5 2.8 3.2		
																												15 25 30	504 450 409.5
15 25 30	560 500 455	50.5 57 55	45.3 60 67.6	75	2.7 3 3.4	46-50×8		30 46 55	440 400 368	58 67 68	61.9 5 74.7 6 81.0 3	90	2.5 2.8 3.2																
														15 25 30	616 550 500.5	50.5 57 55	49.8 66 74.3	90	2.7 3 3.4	46-50×9		30 46 55	499.5 450 414	58 67 68	70.3 3 84.1 0 91.1 5	110	2.5 2.8 3.2		
																												15 25 30	672 600 546

## 性能参数表 Performance parameter list

型 号	转速 n (r/min)	流量 Q (m³/h)	扬程 H (m)	效率 η (%)	功率 (kW)		气蚀余量 (NPSH)r (m)	型 号	转速 n (r/min)	流量 Q (m³/h)	扬程 H (m)	效率 η (%)	功率 (kW)		气蚀余量 (NPSH) r (m)	
					轴 功率	电机 功率							轴 功率	电机 功率		
25-80×6	29.1	17.4	508	41.4	57.9	90	3.1	46-50×11	2950	30	610.5	58	85.9	132	2.5	
		25	475	48	67.5					102.79	2.8					
		29.1	452	51.8	69.5					111.41			3.2			
25-80×7	29.1	17.4	590	41.4	67.5	90	3.1	46-50×12	2950	30		666		58	93.7	132
		25	555	48	78.9					112.14	2.8					
		29.1	530	51.8	81.1					121.54		3.2				
25-80×8	29.1	17.4	675	41.4	77.5	110	3.1	46-80×6	2950	27			528	59	65.8	132
		25	635	48	90.2					99	4					
		29.1	605	51.8	92.5					103		5.5				
25-80×9	29.1	17.4	760	41.4	87	132	3.1	46-80×7	2950	27			615	59	76.9	160
		25	715	48	100					111	4					
		29.1	680	51.8	105					120		5.5				
25-80×10	29.1	17.4	840	41.4	96.5	132	3.1	46-80×8	2950	27			704	59	87.8	160
		25	795	48	113					125	4					
		29.1	755	51.8	117					138		5.5				
25-80×11	29.1	17.4	928	41.4	105	160	3.1	46-80×9	2950	27			792	59	98.8	220
		25	875	48	125					141	4					
		29.1	830	51.8	128					155		5.5				
25-80×12	29.1	17.4	1013	41.4	116	160	3.1	46-80×10	2950	27			880	59	110	220
		25	945	48	136					157	4					
		29.1	905	51.8	140					172		5.5				
46-30×3	2950	30	102	68	12.25	22	2.4	85-45×2	2950	55			102	67	22.7	37
		46	90	74	15.23					27.4	4.2					
		55	81	72	16.84					28.69		5.2				
46-30×4	2950	30	136	68	16.332	30	2.4	85-45×3	2950	55			153	67	34.1	55
		46	120	74	0.31					41.1	4.2					
		55	108	72	22.46					43.04		5.2				
46-30×5	2950	30	170	68	20.42	30	2.4	85-45×4	2950	55			204	67	45.5	75
		46	150	74	25.38					54.8	4.2					
		55	135	72	28.07					57.39		5.2				
46-30×6	2950	30	204	68	24.50	37	2.4	85-45×5	2950	55			255	67	56.9	90
		46	180	74	30.46					68.5	4.2					
		55	162	72	33.69					71.73		5.2				
46-30×7	2950	30	238	68	28.58	45	2.4	85-45×6	2950	55			306	67	68.3	110
		46	210	74	35.54					82.2	4.2					
		55	189	72	39.30					86.08		5.2				
46-30×8	2950	30	274	68	32.91	55	2.4	85-45×7	2950	55			357	67	79.7	132
		46	240	74	40.61					95.9	4.2					
		55	216	72	44.92					100.43		5.2				

## 性能参数表 Performance parameter list

型 号	转速 n (r/min)	流量 Q (m³/h)	扬程 H (m)	效率 η (%)	功率 (kW)		气蚀余量 (NPSH) r (m)	型 号	转速 n (r/min)	流量 Q (m³/h)	扬程 H (m)	效率 η (%)	功率 (kW)		气蚀余量 (NPSH) r (m)		
					轴 功率	电机 功率							轴 功率	电机 功率			
46-30×9		30	306	68	36.75	55	2.4	85-45×8					67	91.1	132	3.2	
		46	270	74	45.69		3.0							109.61			4.2
		55	243	72	50.53		4.6							114.77			
85-45×9		55	459	67	102.57	160	3.2	155-30×10				75	117.96	200	3.2		
		85	405	76	123.31		4.2						158.23			3.9	
		100	351	74	129.12		5.2						174.21				4.8
85-67×2		55	152	60	37.93	55	3.0	155-67×3				67	92.6	132	3.8		
		85	134	71	43.67		3.5						110.1411			4.9	
		100	118	69	46.55		4.0						141.8.85				6.0
85-67×3		55	228	60	56.89	75	3.0	155-67×4				67	123.52	200	3.8		
		85	201	71	65.51		3.5						146.86			4.9	
		100	177	69	69.83		4.0						158.47				6.0
85-67×4		55	304	60	75.86	110	3.0	155-67×5				67	154.39	220	3.8		
		85	268	71	87.34		3.5						183.57			4.9	
		100	236	69	93.11		4.0						198.09				6.0
85-67×5		55	380	60	94.82	132	3.0	155-67×6				67	185.27	280	3.8		
		85	335	71	109.18		3.5						220.29			4.9	
		100	295	69	116.38		4.0						237.70				6.0
85-67×6	2950	55	456	60	113.79	160	3.0	155-67×7				67	216.15	315	3.8		
		85	402	71	131.01		3.5						257.00			4.9	
		100	354	69	139.66		4.0						277.32				6.0
85-67×7		55	532	60	132.75	200	3.0	155-67×8				67	247.03	355	3.2		
		85	469	71	152.85		3.5						293.7231			5.0	
		100	413	69	162.94		4.0						6.94				6.6
85-67×8		55	608	60	151.72	200	3.0	155-67×9				67	277.91	400	3.2		
		85	536	71	174.68		3.5						330.43			5.0	
		100	472	69	186.22		4.0						356.56				6.6
85-67×9		55	684	60	170.68	220	3.0	155-100×6				59	274	400	3.8		
		85	603	71	196.52		3.5						336			4.5	
		100	531	69	209.49		4.0						393				5
85-80×7		51	616	59	145	250	3.5	155-100×7				59	320	500	3.8		
		85	560	70	185		4.5						392			4.5	
		102	532	71	208		4.3						460				5
85-80×8		51	704	59	166	280	3.5	155-100×8				59	366	630	3.8		
		85	640	70	212		4.5						448			4.5	
		102	608	71	238		4.3						491				5
85-80×9		51	792	59	186	315	3.5	155-100×9				59	411	630	3.8		
		85	720	70	238		4.5						504			4.5	
		102	684	71	268		4.3						590				5

## 性能参数表 Performance parameter list

型 号	转速 n (r/min)	流量 Q (m³/h)	扬程 H (m)	效率 η (%)	功率 (kW)		气蚀余量 (NPSH)r (m)	型 号	转速 n (r/min)	流量 Q (m³/h)	扬程 H (m)	效率 η (%)	功率 (kW)		气蚀余量 (NPSH) r (m)
					轴 功率	电机 功率							轴 功率	电机 功率	
85-80×10	1480	51	880	59	207	355	3.5	155-100× 10	1480	120	1100	59	457	800	3.8
		85	800	70	265		4.5			150	1000	73	560		4.5
		102	760	71	295		4.3			180	950	71	656		5
85-80×11	1480	51	949.8	59	225	355	3.5	240-30×2	1480	200	66	72	50	75	2.7
		85	880	70	291		4.5			240	60	75	54.5		3
		102	834.5	71	327		4.3			280	49	68	59		3.6
85-80×12	1480	51	1035	59	245	400	3.5	240-30×3	1480	200	99.	72	75	90	2.7
		85	960	70	318		4.5			240	90	75	81.8		3
		102	905	71	355		4.3			280	73.5	68	88.5		3.6
155-30×2	1480	100	65	75	23.59	45	3.2	240-30×4	1480	200	133	72	100	132	2.7
		155	60	80	31.65		3.9			240	120	75	109		3
		185	55	79.5	34.84		4.8			280	98	68	118		3.6
155-30×3	1480	100	97.5	75	35.39	75	3.2	240-30×5	1480	200	166.	72	125	160	2.7
		155	90	80	47.47		3.9			240	150	75	136.3		3
		185	82.5	79.5	52.26		4.8			280	122	68	147.5		3.6
155-30×4	1480	100	130	75	47.19	90	3.2	240-30×6	1480	200	199	72	150	200	2.7
		155	120	80	63.29		3.9			240	180	75	163.5		3
		185	110	79.5	69.68		4.8			280	147	68	177		3.6
155-30×5	1480	100	162.5	75	58.98	110	3.2	240-30×7	1480	200	232.	72	175	220	2.7
		155	150	80	79.11		3.9			240	210	75	190.8		3
		185	137.5	79.5	87.10		4.8			280	171	68	206.5		3.6
155-30×6	1480	100	195	75	70.78	132	3.2	240-30×8	1480	200	266	72	200	250	2.7
		155	180	80	94.94		3.9			240	240	75	218		3
		185	165	79.5	104.52		4.8			280	196	68	236		3.6
155-30×7	1480	100	234	75	84.93	160	3.2	240-30×9	1480	200	299	72	225	280	2.7
		155	210	80	110.76		3.9			240	270	75	245.3		3
		185	190	79.5	120.36		4.8			280	220	68	265.5		3.6
155-30×8	1480	100	260	72	94.37	160	3.2	240-30×10	1480	200	332	72	250	315	2.7
		155	240	77	126.58		3.9			240	300	75	272.5		3
		185	220	76.5	139.36		4.8			280	245	68	295		3.6
155-30×9	1480	100	292.5	72	106.17	200	3.2	280-43×2	1480	185	94	72	65.7	110	3.0
		155	270	77	142.41		3.9			280	86	80	81.9		4.7
		185	247.5	76.5	156.78		4.8			335	76	78	88.8		6.0
280-43×3	1480	185	141	72	98.62	160	3.0	300-31×2	1480	250	70	72	69.4	90	3.0
		280	129	80	122.91		4.7			300	62	73	73.5		3.2
		335	114	78	133.28		6.0			350	52	71	75.8		3.7
280-43×4	1480	185	188	72	131.50	200	3.0	300-31×3	1480	250	106	72	104	132	3.0
		280	172	80	163.88		4.7			300	94	73	110		3.2
		335	152	78	177.71		6.0			350	80	71	113		3.7
280-43×5	1480	185	235	72	164.37	250	3.0	300-31×4	1480	250	142	72	138	160	3.0
		280	215	80	204.85		4.7			300	126	73	147		3.2
		335	190	78	222.14		6.0			350	107	71	151		3.7
280-43×6	1480	185	282	72	197.25	315	3.0	300-31×5	1480	250	178	72	173	200	3.0
		280	258	80	245.82		4.7			300	157	73	183		3.2
		335	228	78	266.57		6.0			350	133	71	189		3.7

## 性能参数表 Performance parameter list

型 号	转速 n (r/min)	流量 Q (m³/h)	扬程 H (m)	效率 η (%)	功率 (kW)		气蚀余量 (NPSH)r (m)	型 号	转速 n (r/min)	流量 Q (m³/h)	扬程 H (m)	效率 η (%)	功率 (kW)		气蚀余量 (NPSH) r (m)
					轴 功率	电机 功率							轴 功率	电机 功率	
280-43×7	1480	185	329	72	230.12	355	3.0	300-31×6	1480	250	213	72	208	250	3.0
		280	301	80	286.79		4.7			300	189	73	220		3.2
		335	266	78	311.00		6.0			350	160	71	227		3.7
280-43×8	1480	185	376	72	263.00	400	3.0	300-31×7	1480	250	249	72	243	270	3.0
		280	344	80	327.76		4.7			300	220	73	257		3.2
		335	304	78	355.42		6.0			350	187	71	265		3.7
280-43×9	1480	185	423	72	295.87	450	3.0	300-31×8	1480	250	284	72	277	315	3.0
		280	387	80	368.73		4.7			300	252	73	294		3.2
		335	342	78	399.85		6.0			350	214	71	303		3.7
280-65×2	1480	185	136	64	107.02	160	2.8	300-31×9	1480	250	320	72	312	355	3.0
		280	130	76	130.38		3.7			300	283	73	330		3.2
		335	124	78	144.98		5.0			350	240.5	71	341		3.7
280-65×3	1480	185	204	64	160.53	250	2.8	300-31×10	1480	250	356	72	347	400	3.0
		280	195	76	195.57		3.7			300	315	73	367		3.2
		335	186	78	217.46		5.0			350	267	71	379		3.7
280-65×4	1480	185	272	64	214.03	315	2.8	300-65×2	1480	230	137.2	69.2	124.2	200	3.5
		280	260	76	260.76		3.7			300	130	73.8	143.9		3.7
		335	248	78	289.95		5.0			360	120.6	73.5	160.9		4.2
280-65×5	1480	185	340	64	267.54	400	2.8	300-65×3	1480	230	205.8	69.2	186.3	280	3.5
		280	325	76	325.95		3.7			300	195	73.8	215.9		3.7
		335	310	78	362.44		5.0			360	180.9	73.5	241.3		4.2
280-65×6	1480	185	408	64	321.05	500	2.8	300-65×4	1480	230	274.4	69.2	248.4	355	3.5
		280	390	76	391.14		3.7			300	260	73.8	287.8		3.7
		335	372	78	434.93		5.0			360	241.2	73.5	321.7		4.2
280-65×7	1480	185	476	64	374.56	630	2.8	300-65×5	1480	230	343	69.2	310.5	450	3.5
		280	455	76	456.33		3.7			300	325	73.8	359.8		3.7
		335	434	78	507.42		5.0			360	301.5	73.5	402.2		4.2
280-65×8	1480	185	544	64	428.07	710	2.8	300-65×6	1480	230	411.6	69.2	372.6	560	3.5
		280	520	76	521.52		3.7			300	390	73.8	431.7		3.7
		335	496	78	579.90		5.0			360	361.8	73.5	482.6		4.2
280-65×9	1480	185	612	64	481.58	800	2.8	300-65×7	1480	230	480.2	69.2	434.7	630	3.5
		280	585	76	586.71		3.7			300	455	73.8	503.7		3.7
		335	558	78	652.39		5.0			360	422.1	73.5	563.0		4.2
280-65×10	1480	185	680	64	535.09	800	2.8	300-65×8	1480	230	548.8	69.2	496.7	710	3.5
		280	650	76	661.09		3.7			300	520	73.8	575.7		3.7
		335	620	78	724.88		5.0			360	482.4	73.5	643.5		4.2
280-100×4	1480	250	420	74	386.4	450	5.1	300-65×9	1480	230	617.4	69.2	558.8	800	3.5
		280	400	77	396		5.6			300	585	73.8	647.6		3.7
		300	392	77	416		5.9			360	542.7	73.5	723.9		4.2

## 性能参数表 Performance parameter list

型 号	转速 n (r/min)	流量 Q (m³/h)	扬程 H (m)	效率 η (%)	功率 (kW)		气蚀余量 (NPSH)r (m)	型 号	转速 n (r/min)	流量 Q (m³/h)	扬程 H (m)	效率 η (%)	功率 (kW)		气蚀余量 (NPSH) r (m)
					轴 功率	电机 功率							轴 功率	电机 功率	
280-43×7		185	329	72	230.12	355	3.0	300-31×6		250	213	72	208	250	3.0
		280	301	80	286.79		4.7			300	189	73	220		3.2
		335	266	78	311.00		6.0			350	160	71	227		3.7
280-43×8		185	376	72	263.00	400	3.0	300-31×7		250	249	72	243	270	3.0
		280	344	80	327.76		4.7			300	220	73	257		3.2
		335	304	78	355.42		6.0			350	187	71	265		3.7
280-43×9		185	423	72	295.87	450	3.0	300-31×8		250	284	72	277	315	3.0
		280	387	80	368.73		4.7			300	252	73	294		3.2
		335	342	78	399.85		6.0			350	214	71	303		3.7
280-65×2		185	136	64	107.02	160	2.8	300-31×9		250	320	72	312	355	3.0
		280	130	76	130.38		3.7			300	283	73	330		3.2
		335	124	78	144.98		5.0			350	240.5	71	341		3.7
280-65×3		185	204	64	160.53	250	2.8	300-31×10		250	356	72	347	400	3.0
		280	195	76	195.57		3.7			300	315	73	367		3.2
		335	186	78	217.46		5.0			350	267	71	379		3.7
280-65×4	1480	185	272	64	214.03	315	2.8	300-65×2		230	137.2	69.2	124.2	200	3.5
		280	260	76	260.76		3.7			300	130	73.8	143.9		3.7
		335	248	78	289.95		5.0			360	120.6	73.5	160.9		4.2
280-65×5		185	340	64	267.54	400	2.8	300-65×3		230	205.8	69.2	186.3	280	3.5
		280	325	76	325.95		3.7			300	195	73.8	215.9		3.7
		335	310	78	362.44		5.0			360	180.9	73.5	241.3		4.2
280-65×6		185	408	64	321.05	500	2.8	300-65×4		230	274.4	69.2	248.4	355	3.5
		280	390	76	391.14		3.7			300	260	73.8	287.8		3.7
		335	372	78	434.93		5.0			360	241.2	73.5	321.7		4.2
280-65×7	1480	185	476	64	374.56	630	2.8	300-65×5		230	343	69.2	310.5	450	3.5
		280	455	76	456.33		3.7			300	325	73.8	359.8		3.7
		335	434	78	507.42		5.0			360	301.5	73.5	402.2		4.2
280-65×8		185	544	64	428.07	710	2.8	300-65×6		230	411.6	69.2	372.6	560	3.5
		280	520	76	521.52		3.7			300	390	73.8	431.7		3.7
		335	496	78	579.90		5.0			360	361.8	73.5	482.6		4.2
280-65×9		185	612	64	481.58	800	2.8	300-65×7		230	480.2	69.2	434.7	630	3.5
		280	585	76	586.71		3.7			300	455	73.8	503.7		3.7
		335	558	78	652.39		5.0			360	422.1	73.5	563.0		4.2
280-65×10		185	680	64	535.09	800	2.8	300-65×8		230	548.8	69.2	496.7	710	3.5
		280	650	76	661.09		3.7			300	520	73.8	575.7		3.7
		335	620	78	724.88		5.0			360	482.4	73.5	643.5		4.2
280-100×4		250	420	74	386.4	450	5.1	300-65×9		230	617.4	69.2	558.8	800	3.5
		280	400	77	396		5.6			300	585	73.8	647.6		3.7
		300	392	77	416		5.9			360	542.7	73.5	723.9		4.2

280-100×5		250	525	74	483	630	5.1	300-65×10		230	686	69.2	620.9	900	3.5
		280	500	77	495		5.6			300	650	73.8	719.6		3.7
		300	490	77	520		5.9			360	603	73.5	804.3		4.2
280-100×6		250	630	74	579.6	710	5.1	300-65×11		230	754.6	69.2	683.0	900	3.5
		280	600	77	594		5.6			300	715	73.8	791.5		3.7
		300	588	77	624		5.9			360	663.3	73.5	884.8		4.2
280-100×7		250	735	74	676.2	800	5.1	300-65×12		230	823.2	69.2	745.1	1000	3.5
		280	700	77	693		5.6			300	780	73.8	863.5		3.7
		300	686	77	728		5.9			360	723.6	73.5	965.2		4.2
280-100×8		250	840	74	772.8	1000	5.1	360-60×2	1480	250	130	67.5	131.1	200	3.7
		280	800	77	792		5.6			360	120	76.7	153.4		4.3
		300	784	77	832		5.9			420	110.6	75.0	168.7		4.7
280-100×9		250	945	74	869.4	1120	5.1	360-60×3		250	195	67.5	196.7	280	3.7
		280	900	77	891		5.6			360	180	76.7	230.1		4.3
		300	882	77	936		5.9			420	165.9	75.0	253.0		4.7
280-100×10		250	1050	74	966	1250	5.1	360-60×4		250	260	67.5	262.2	400	3.7
		280	1000	77	990		5.6			360	240	76.7	306.8		4.3
		300	950	77	1040		5.9			420	221.2	75.0	337.3		4.7

360-60×5	1480	250	325	67.5	327.8	450	3.7	450-60×5	1480	335	319	75	387.88	560	4.6
		360	300	76.7	383.5		4.3			450	300	79.5	462.26		4.9
		420	276.5	75.0	421.7		4.7			500	271.5	78	473.77		5.3
360-60×6		250	390	67.5	393.4	560	3.7	450-60×6		335	382.8	75	465.46	630	4.6
		360	360	76.7	460.2		4.3			450	360	79.5	554.72		4.9
		420	331.8	75.0	506.0		4.7			500	325.8	78	568.53		5.3
360-60×7		250	455	67.5	458.9	630	3.7	450-60×7		335	446.6	75	543.03	800	4.6
		360	420	76.7	536.9		4.3			450	420	79.5	647.17		4.9
		420	387.1	75.0	590.3		4.7			500	380.1	78	663.28		5.3
360-60×8		250	520	67.5	524.5	800	3.7	450-60×8		335	510.4	75	620.61	900	4.6
		360	480	76.7	613.5		4.3			450	480	79.5	739.62		4.9
		420	442.4	75.0	674.7		4.7			500	434.4	78	758.03		5.3
360-60×9		250	585	67.5	590.1	900	3.7	450-60×9		335	574.2	75	698.18	1000	4.6
		360	540	76.7	690.2		4.3			450	540	79.5	832.08		4.9
		420	497.7	75.0	759.0		4.7			500	488.7	78	852.79		5.3
360-60×10		250	650	67.5	655.6	900	3.7	450-60×10		335	638	75	775.76	1120	4.6
		360	600	76.7	766.9		4.3			450	600	79.5	924.53		4.9
		420	553	75.0	843.4		4.7			500	543	78	947.54		5.3
360-60×11		250	715	67.5	721.2	1000	3.7	450-60×11		335	701.8	75	853.34	1250	4.6
		360	660	76.7	843.6		4.3			450	660	79.5	1016.9		4.9
		420	608.3	75.0	927.7		4.7			500	597.3	78	1042.3		5.3
360-60×12		250	780	67.5	786.7	1120	3.7	450-60×12		335	765.6	75	930.91	1400	4.6
		360	720	76.7	920.3		4.3			450	720	79.5	1109.4		4.9
		420	663.6	75.0	1012.0		4.7			500	651.6	78	1137.0		5.3
420-95×2	1480	320	217	72.5	260.8	355	4.1	450-95×2		335	214	73.0	267.61	400	4.4
		420	190	73.4	296.1		4.5			450	190	74.4	313.16		4.8
		480	167.2	69.4	314.9		4.9			500	166	69.5	325.43		5.2
420-95×3		320	325.5	72.5	391.3	560	4.1	450-95×3		335	321	73.0	401.41	560	4.4
		420	285	73.4	444.1		4.5			450	285	74.4	469.73		4.8
		480	250.8	69.4	472.4		4.9			500	249	69.5	488.15		5.2
420-95×4		320	434	72.5	521.7	710	4.1	450-95×4		335	428	73.0	535.22	800	4.4
		420	380	73.4	592.2		4.5			450	380	74.4	626.31		4.8
		480	334.4	69.4	629.9		4.9			500	332	69.5	650.86		5.2
420-95×5		320	542.5	72.5	652.1	900	4.1	450-95×5		335	535	73.0	669.02	1000	4.4
		420	475	73.4	740.2		4.5			450	475	74.4	782.89		4.8
		480	418	69.4	787.3		4.9			500	415	69.5	813.58		5.2
420-95×6		320	651	72.5	782.5	1120	4.1	450-95×6		335	642	73.0	802.83	1120	4.4
		420	570	73.4	888.2		4.5			450	570	74.4	939.47		4.8
		480	501.6	69.4	944.8		4.9			500	498	69.5	976.29		5.2
420-95×7		320	759.5	72.5	912.9	1250	4.1	450-95×7		335	749	73.0	936	1400	4.4
		420	665	73.4	1036.3		4.5			450	665	74.4	1096		4.8
		480	585.2	69.4	1102.3		4.9			500	581	69.5	1139		5.2
420-95×8		320	868	72.5	1043.3	1400	4.1	450-95×8		335	856	73.0	1070	1600	4.4
		420	760	73.4	1184.3		4.5			450	760	74.4	1252		4.8
		480	668.8	69.4	1259.7		4.9			500	664	69.5	1301		5.2
420-95×9		320	976.5	72.5	1173.8	1600	4.1	450-95×9		335	963	73.0	1204	1800	4.4
		420	855	73.4	1332.3		4.5			450	855	74.4	1409		4.8
		480	752.4	69.4	1417.2		4.9			500	747	69.5	1464		5.2
420-95×10		320	1085	72.5	1304.2	1800	4.1	450-95×10		335	1070	73.0	1338	2000	4.4
		420	950	73.4	1480.4		4.5			450	950	74.4	1565		4.8
		480	836	69.4	1574.7		4.9			500	830	69.5	1627		5.2

420-95×11		320	1193	72.5	1434.6	2000	4.1	450-95×11		335	1177	73.0	1471	2000	4.4	
		420	1045	73.4	1628.4					450	1045	74.4	1722			4.8
		480	919.6	69.4	1732.1					500	913	69.5	1789			5.2
420-95×12		320	1302	72.5	1565.0	2240	4.1	450-95×12		335	1284	73.0	1605	2240	4.4	
		420	1140	73.4	1776.5					450	1140	74.4	1878			4.8
		480	1004	69.4	1889.6					500	996	69.5	1952			5.2
450-60×2		335	127.6	75	155.15	250	4.6	500-40×2	1480	360	88.8	73.6	118.3	160	4.9	
		450	120	79.5	184.91					500	80	81.5	133.7			5.5
		500	108.6	78	189.51					600	70.4	80.7	142.5			6.2
450-60×3		335	191.4	75	232.73	355	4.6	500-40×3	1480	360	133.2	73.6	177.4	250	4.9	
		450	180	79.5	277.36					500	120	81.5	200.5			5.5
		500	162.9	78	284.26					600	105.6	80.7	213.8			6.2
450-60×4		335	255.2	75	310.30	450	4.6	500-40×4	1480	360	177.6	73.6	236.6	315	4.9	
		450	240	79.5	369.81					500	160	81.5	267.3			5.5
		500	217.2	78	379.02					600	140.8	80.7	285.1			6.2

500-40×5		360	222	73.6	295.7	400	4.9	600-60×5		440	340	78.6	518.3	800	5.3	
		500	200	81.5	334.1					600	300	81.3	602.9			6.2
		600	176	80.7	356.4					690	270	77.5	654.6			6.8
500-40×6		360	266.4	73.6	354.9	500	4.9	600-60×6		440	408	78.6	622.0	900	5.3	
		500	240	81.5	401.0					600	360	81.3	723.5			6.2
		600	211.2	80.7	427.6					690	324	77.5	785.6			6.8
500-40×7		360	310.8	73.6	414.0	560	4.9	600-60×7		440	476	78.6	725.7	1120	5.3	
		500	280	81.5	467.8					600	420	81.3	844.1			6.2
		600	246.4	80.7	498.9					690	378	77.5	916.5			6.8
500-40×8		360	355.2	73.6	473.1	630	4.9	600-60×8		440	544	78.6	829.3	1250	5.3	
		500	320	81.5	534.6					600	480	81.3	964.7			6.2
		600	281.6	80.7	570.2					690	432	77.5	1047.4			6.8
500-40×9	1480	360	399.6	73.6	532.3	710	4.9	600-60×9	1480	440	612	78.6	933.0	1400	5.3	
		500	360	81.5	601.5					600	540	81.3	1085.3			6.2
		600	316.8	80.7	641.4					690	486	77.5	1178.4			6.8
500-40×10		360	444	73.6	591.4	800	4.9	600-60×10		440	680	78.6	1036.7	1600	5.3	
		500	400	81.5	668.3					600	600	81.3	1205.9			6.2
		600	352	80.7	712.7					690	540	77.5	1309.3			6.8
500-40×11		360	488.4	73.6	650.6	900	4.9	600-60×11		440	748	78.6	1140.3	1600	5.3	
		500	440	81.5	735.1					600	660	81.3	1326.5			6.2
		600	387.2	80.7	784.0					690	594	77.5	1440.2			6.8
500-40×12		360	532.8	73.6	709.7	1000	4.9	600-60×12		440	816	78.6	1244.0	1800	5.3	
		500	480	81.5	802.0					600	720	81.3	1447.1			6.2
		600	422.4	80.7	855.3					690	648	77.5	1571.2			6.8
550-50×2		450	110	76.5	176.32	220	5.3	650-80×2		480	176	75.9	303.1	450	5.2	
		550	100	81.5	183.90					650	160	80.1	353.6			6.3
		590	94.6	79.0	192.52					770	140	76.8	382.3			7.2
550-50×3		450	165	76.5	264.49	355	5.3	650-80×3		480	264	75.9	454.7	630	5.2	
		550	150	81.5	275.84					650	240	80.1	530.4			6.3
		590	141.9	79.0	288.78					770	210	76.8	573.4			7.2
550-50×4		450	220	76.5	352.65	450	5.3	650-80×4		480	352	75.9	606.2	900	5.2	
		550	200	81.5	367.79					650	320	80.1	707.2			6.3
		590	189.2	79.0	385.05					770	280	76.8	764.5			7.2
550-50×5		450	275	76.5	440.81	560	5.3	650-80×5		480	440	75.9	757.8	1120	5.2	
		550	250	81.5	459.74					650	400	80.1	884.0			6.3
		590	236.5	79.0	481.31					770	350	76.8	955.6			7.2
550-50×6		450	330	76.5	528.97	710	5.3	650-80×6		480	528	75.9	909.3	1250	5.2	
		550	300	81.5	551.69					650	480	80.1	1060.8			6.3
		590	283.8	79.0	577.57					770	420	76.8	1146.8			7.2
550-50×7	1480	450	385	76.5	617.13	800	5.3	650-80×7		480	616	75.9	1060.9	1600	5.2	
		550	350	81.5	643.63					650	560	80.1	1237.6			6.3
		590	331.1	79.0	673.83					770	490	76.8	1337.9			7.2
550-50×8		450	440	76.5	705.29	900	5.3	650-80×8		480	704	75.9	1212.5	1800	5.2	
		550	400	81.5	735.58					650	640	80.1	1414.4			6.3
		590	378.4	79.0	770.09					770	560	76.8	1529.0			7.2
550-50×9		450	495	76.5	793.46	1000	5.3	650-80×9		480	792	75.9	1364.0	2000	5.2	
		550	450	81.5	827.53					650	720	80.1	1591.1			6.3
		590	425.7	79.0	866.35					770	630	76.8	1720.2			7.2
550-50×10		450	550	76.5	881.62	1120	5.3	650-80×10	1480	480	880	75.9	1515.6	2240	5.2	
		550	500	81.5	919.48					650	800	80.1	1767.9			6.3
		590	473	79.0	962.61					770	700	76.8	1911.3			7.2
550-50×11		450	605	76.5	969.78	1250	5.3	650-80×11		480	968	75.9	1667.1	2240	5.2	
		550	550	81.5	1011					650	880	80.1	1944.7			6.3
		590	520.3	79.0	1058					770	770	76.8	2102.4			7.2
550-50×12		450	660	76.5	1057	1400	5.3	650-80×12		480	1056	75.9	1818.7	2500	5.2	
		550	600	81.5	1103					650	960	80.1	2121.5			6.3
		590	567.6	79.0	1155					770	840	76.8	2293.5			7.2

600-60×2		440	136	78.6	207.3	315	5.3	720-60×2	1480	550	134.2	79.7	252.2	355	6.1
		600	120	81.3	241.2		6.2			720	120	82.4	285.6		6.6
		690	108	77.5	261.9		6.8			850	106.8	79.2	312.1		7.6
600-60×3		440	204	78.6	311.0	450	5.3	720-60×3	1480	550	201.3	79.7	378.3	560	6.1
		600	180	81.3	361.8		6.2			720	180	82.4	428.3		6.6
		690	162	77.5	392.8		6.8			850	160.2	79.2	468.2		7.6
600-60×4		440	272	78.6	414.7	630	5.3	720-60×4	1480	550	268.4	79.7	504.4	710	6.1
		600	240	81.3	482.4		6.2			720	240	82.4	571.1		6.6
		690	216	77.5	523.7		6.8			850	213.6	79.2	624.3		7.6

720-60×5	1480	550	335.5	79.7	630.5	900	6.1	1300-60×2	960	756	139	66	443	630	6.3
		720	300	82.4	713.9		6.6			1300	120	82	528.5		6.5
		850	267	79.2	780.4		7.6			1600	98	76	573		7.0
720-60×6	1480	550	402.6	79.7	756.6	1000	6.1	1300-60×3	960	756	208.5	66	663.4	900	6.3
		720	360	82.4	856.7		6.6			1300	180	82	792.7		6.5
		850	320.4	79.2	936.4		7.6			1600	147	76	859.6		7.0
720-60×7	1480	550	469.7	79.7	882.7	1250	6.1	1300-60×4	960	756	278	66	884.5	1250	6.3
		720	420	82.4	999.4		6.6			1300	240	82	1056.9		6.5
		850	373.8	79.2	1092.5		7.6			1600	196	76	1146		7.0
720-60×8	1480	550	536.8	79.7	1008.8	1400	6.1	1300-60×5	960	756	347.5	66	1105.7	1600	6.3
		720	480	82.4	1142.2		6.6			1300	300	82	1321.1		6.5
		850	427.2	79.2	1248.6		7.6			1600	255	76	1491.2		7.0
720-60×9	1480	550	603.9	79.7	1134.9	1600	6.1	2000-60×2	960	1250	139	78	618.8	900	6.1
		720	540	82.4	1285.0		6.6			2000	120	84	793.7		6.6
		850	480.6	79.2	1404.7		7.6			2550	98	82	846.5		7.6
720-60×10	1480	550	671	79.7	1261.0	1800	6.1	2000-60×3	960	1250	208.5	78	928.2	1400	6.1
		720	600	82.4	1427.8		6.6			2000	180	84	1190.5		6.6
		850	534	79.2	1560.7		7.6			2550	147	82	1269.8		7.6
720-60×11	1480	550	738.1	79.7	1387.1	1800	6.1	2000-60×4	960	1250	278	78	1237.5	1800	6.1
		720	660	82.4	1570.5		6.6			2000	240	84	1587.3		6.6
		850	587.4	79.2	1716.8		7.6			2550	196	82	1693.1		7.6
720-60×12	1480	550	805.2	79.7	1513.2	2000	6.1	2000-60×5	960	1250	347.5	78	1546.9	2500	6.1
		720	720	82.4	1713.3		6.6			2000	300	84	1984.2		6.6
		850	640.8	79.2	1872.9		7.6			2550	255	82	2202.7		7.6
800-60×2	1480	600	134	78.1	280.52	400	6.6	3000-60×2	740	1905	139	80	919.4	1400	5.9
		800	120	83.0	315.18		7.1			3000	120	86	1162.8		6.5
		1000	98	77.5	344.58		8.1			3804	98	83	1247.7		7.4
800-60×3	1480	600	201	78.1	420.79	560	6.6	3000-60×3	740	1905	208.5	80	1379.2	2000	5.9
		800	180	83.0	472.77		7.1			3000	180	86	1744.2		6.5
		1000	147	77.5	516.87		8.1			3804	147	83	1871.5		7.4
800-60×4	1480	600	268	78.1	561.05	800	6.6	3000-60×4	740	1905	278	80	1838.9	2800	5.9
		800	240	83.0	630.36		7.1			3000	240	86	2325.6		6.5
		1000	196	77.5	689.16		8.1			3804	196	83	2495.2		7.4
800-60×5	1480	600	335	78.1	701.31	1000	6.6	3000-60×5	740	1905	347.5	80	2298.7	3550	5.9
		800	300	83.0	787.95		7.1			3000	300	86	2907.1		6.5
		1000	245	77.5	861.45		8.1			3804	255	83	3246.3		7.4
800-60×6	1480	600	402	78.1	841.57	1120	6.6	3000-60×6	740	1905	417	80	2758.2	4000	5.9
		800	360	83.0	945.54		7.1			3000	360	86	3488.4		6.5
		1000	294	77.5	1033		8.1			3804	294	83	3742.9		7.4
800-60×7	1480	600	469	78.1	981.84	1400	6.6	4000-50×2	585	2985	110	81	1126.2	1800	6.0
		800	420	83.0	1103		7.1			4000	100	87	1277.1		6.7
		1000	343	77.5	1206		8.1			4980	94.6	84	1557.9		7.6
800-60×8	1480	600	536	78.1	1122	1600	6.6	4000-50×3	585	2985	165	81	1689.1	2500	6.0
		800	480	83.0	1260		7.1			4000	150	87	1915.7		6.7
		1000	392	77.5	1378		8.1			4980	141.9	84	2336.8		7.6
800-60×9	1480	600	603	78.1	1262	1800	6.6	4000-50×4	585	2985	220	81	2252.1	3550	6.0
		800	540	83.0	1418		7.1			4000	200	87	2554.3		6.7
		1000	441	77.5	1550		8.1			4980	189.2	84	3115.8		7.6
800-60×10	1480	600	670	78.1	1402	2000	6.6	4000-50×5	585	2985	275	81	2815.1	4000	6.0
		800	600	83.0	1575		7.1			4000	250	87	3192.8		6.7
		1000	490	77.5	1722		8.1			4980	236.5	84	3894.7		7.6
800-60×11	1480	600	737	78.1	1542	2000	6.6	4000-50×6	585	2985	330	81	3378.1	5000	6.0
		800	660	83.0	1733		7.1			4000	300	87	3831.4		6.7
		1000	539	77.5	1895		8.1			4980	283.8	84	4673.7		7.6
800-60×12	1480	600	804	78.1	1683	2240	6.6	4000-50×7	585	2985	385	81	3941.1	5600	6.0
		800	720	83.0	1891		7.1			4000	350	87	4470.0		6.7
		1000	588	77.5	2067		8.1			4980	331.1	84	5452.6		7.6

## 八、外形尺寸安装图 Outline dimension mounting chart

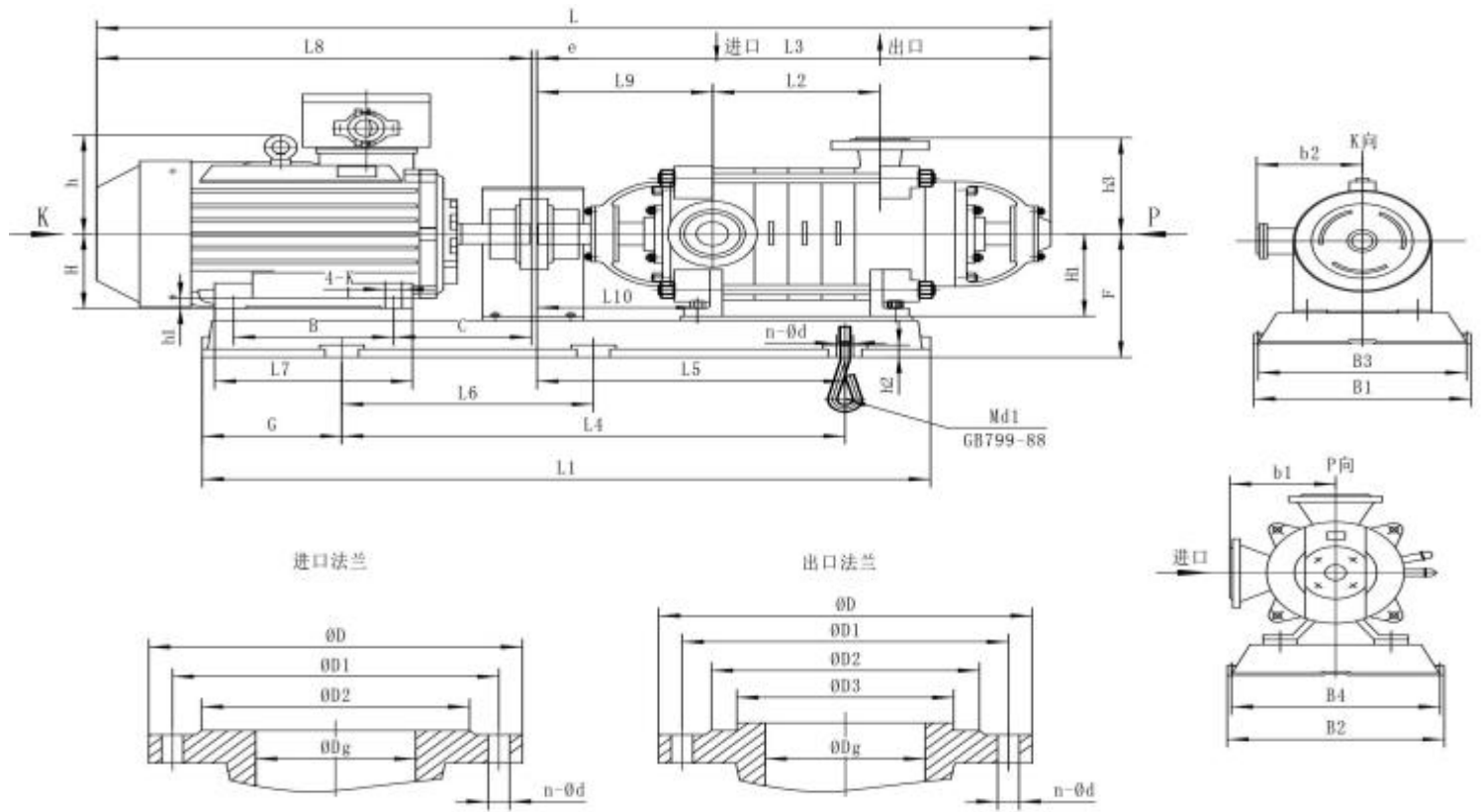

D型多级离心泵外形安装图（电机、泵共同底座）  
Installation diagram of D-type multi-stage centrifugal pump (motor and pump share the same base)

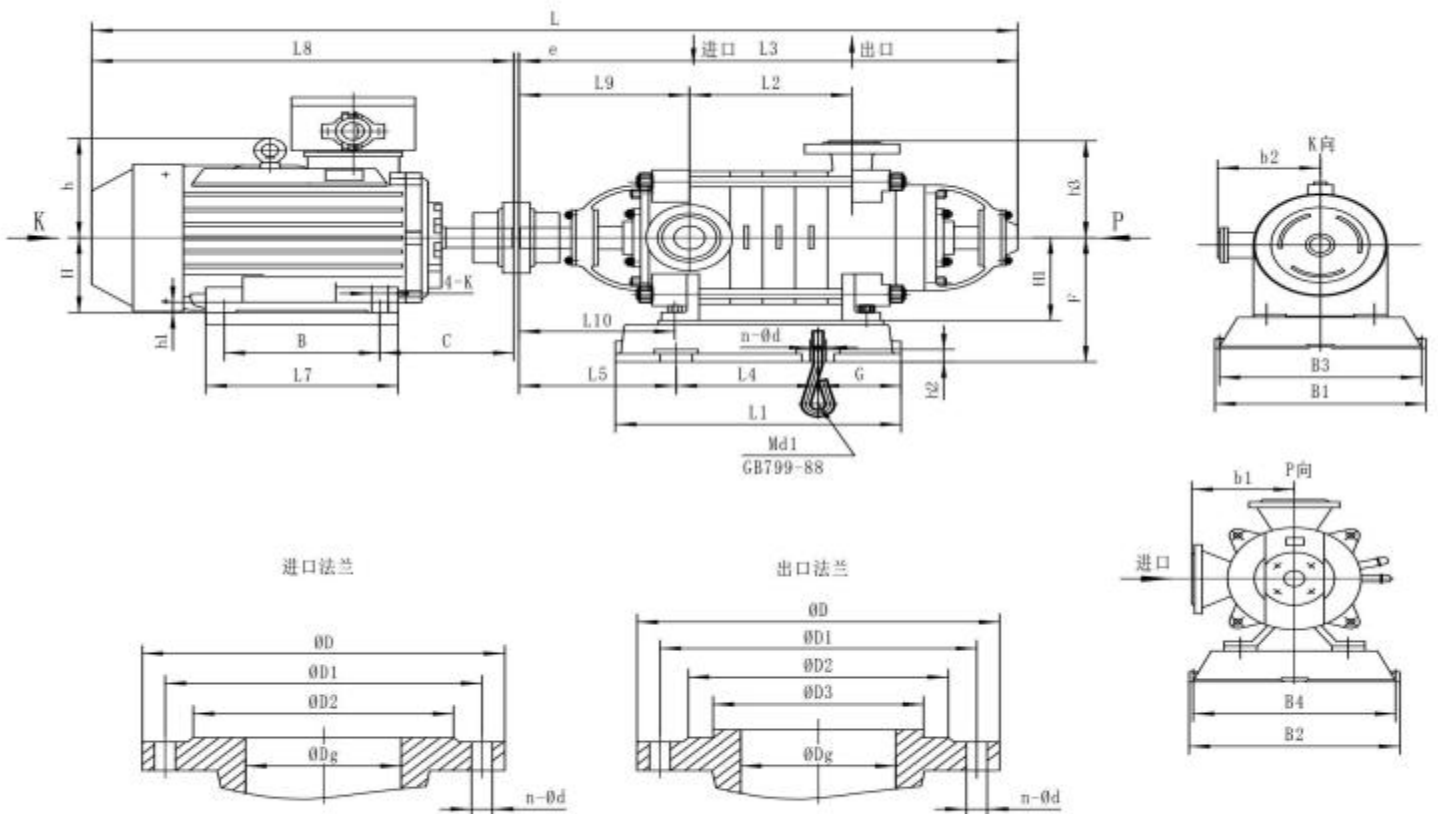

D型多级离心泵外形安装图（单泵底座）  
Installation diagram of D type multi-stage centrifugal pump (single pump base)

## 九、外形安装尺寸表 Outline installation dimension table

D6-25×(3~14) 多级离心泵外形安装尺寸表 (共同底座) Multi-stage centrifugal pump shape installation size table (common base)																						
size model	L	L1	L2	L3	L4	L5	L6	L7	L8	L9	L10	B	B1	B2	B3	B4	b1	b2	C	H	H1	h
D6-25×3	1175	885	180	695	600	358	0	210	475	265	265	140	440	440	390	390	170	210	169	132	150	183
D6-25×4	1225	985	230	745	650	408																
D6-25×5	1275		280	795																		
D6-25×6	1455	1206	330	845	785	459		275	605	210	485	485	435	435	265	218		160	225			
D6-25×7	1505		380	895																		
D6-25×8	1555	1306	430	945	835	509		320	650	254	485	485	435	435	265	218		160	225			
D6-25×9	1605		480	995																		
D6-25×10	1700	1500	530	1045	935	584		320	650	254	485	485	435	435	265	218		160	225			
D6-25×11	1750		580	1095																		
D6-25×12	1800	1600	630	1145	935	584		320	650	254	485	485	435	435	265	218		160	225			
D6-25×13	1850		680	1195																		
D6-25×14	1900	730	1245	684																		

size model	h1	h2	h3	e	k	G	F	n	d	d1	进口法兰尺寸 Imported flange dimensions					出口法兰尺寸 Export flange size					电机型号 Motor model		
											D	D1	D2	Dg	n-φd	D	D1	D2	D3	Dg	n-φd	型号 model	功率(KW)
D6-25×3	20	30	170	5	12	140	230	4	24	M20×400	130	100	80	40	4-φ13.5	150	110	88	75	40	4-φ17.5	YB <sub>2</sub> 132S1-2	5.5
D6-25×4																						YB <sub>2</sub> 132S2-2	7.5
D6-25×5																						YB <sub>2</sub> 160M1-2	11
D6-25×6	22	30	170	5	15	176	240	4	24	M20×400	130	100	80	40	4-φ13.5	150	110	88	75	40	4-φ17.5	YB <sub>2</sub> 160M2-2	15
D6-25×7																						YB <sub>2</sub> 160M1-2	11
D6-25×8																						YB <sub>2</sub> 160M2-2	15
D6-25×9	22	30	170	5	15	176	240	4	24	M20×400	130	100	80	40	4-φ13.5	150	110	88	75	40	4-φ17.5	YB <sub>2</sub> 160L-2	18.5
D6-25×10																						YB <sub>2</sub> 160L-2	18.5
D6-25×11																						YB <sub>2</sub> 160L-2	18.5
D6-25×12																						YB <sub>2</sub> 160L-2	18.5
D6-25×13																						YB <sub>2</sub> 160L-2	18.5
D6-25×14	295																						

D12-25×(3~14) 多级离心泵外形安装尺寸表 (共同底座) multi-stage centrifugal pump external installation dimensions table (common base) (mm)

size model	L	L1	L2	L3	L4	L5	L6	L7	L8	L9	L10	B	B1	B2	B3	B4	b1	b2	C	H	H1	h			
D12-25×3	1175	874	180	695	600	355	0	210	475	265	265	140	445	445	395	395	170	210	169	132	150	183			
D12-25×4	1350	1040	230	745	710	380		275	605			210	480	480	430	430		265	218	160		285	231	180	250
D12-25×5	1400	1090	280	795	730	403																			
D12-25×6	1450	1140	330	845	740	413		320	650			254	241	510	460	400		315	243	200		378	775		
D12-25×7	1500	1190	380	895	780	453																			
D12-25×8	1595	1284	430	945	830	479																			
D12-25×9	1645		480	995																					
D12-25×10	1720	1397	530	1045	870	520		332	670			305	550	500	400	315		243	200	378		775			
D12-25×11	1770	1447	580	1095	900	550																			
D12-25×12	1925	1571	630	1145	980	578		1671	730			1245	1080	678											
D12-25×13	1975	680	1195																						
D12-25×14	2025	730	1245																						

size model	h1	h2	h3	e	k	G	F	n	d	d1	进口法兰尺寸 Imported flange dimensions					出口法兰尺寸 Export flange size					电机型号 Motor model																		
											D	D1	D2	Dg	n-φd	D	D1	D2	D3	Dg	n-φd	型号 model	功率(KW)																
D12-25×3	20	30	170	3	12	134	230	4	25	M20 ×400	140	110	90	50	4-φ13.5	150	110	88	75	40	4-φ17.5	YB <sub>2</sub> 132S2-2	7.5																
D12-25×4	22				165	240	YB <sub>2</sub> 160M1-2															11																	
D12-25×5					168		YB <sub>2</sub> 160M2-2															15																	
D12-25×6					188		YB <sub>2</sub> 160L-2															18.5																	
D12-25×7					190																																		
D12-25×8					24		200															260	YB <sub>2</sub> 180M-2	22															
D12-25×9							27															19	220	280	YB <sub>2</sub> 200L1-2	30													
D12-25×10																																							
D12-25×11																																							
D12-25×12																																							
D12-25×13																																							
D12-25×14																																							

D12-50× (3~12) 多级离心泵外形安装尺寸表 (共同底座) multi-stage centrifugal pump external installation size table (common base) (mm)

size model	L	L1	L2	L3	L4	L5	L6	L7	L8	L9	L10	B	B1	B2	B3	B4	b1	b2	C	H	H1	h
	D12-50×3	1528	1192	259	879	811	469	0	314	645	306	322	254	510	510	460	460	254	255	218	160	200
D12-50×4	1621	1260	327	947	860	504	311		670	241			510	510	460	460	285		231	180	250	
D12-50×5	1794	1425	395	1015	950	554	379		775	305			559	559	509	509	310		243	200	275	
D12-50×6	1862	1493	463	1083	1020	622	379		775	305			559	559	509	509	310		243	200	275	
D12-50×7	1930	1561	531	1151	1088	690	379		775	305			559	559	509	509	310		243	200	275	
D12-50×8	2038	1641	599	1219	1122	711	393		815	311			559	514	549	464	345		259	225	305	
D12-50×9	2106	1709	667	1287	1190	779	393		815	311			559	514	549	464	345		259	225	305	
D12-50×10	2289	1876	735	1355	1242	755	455		930	349			654	524	604	474	385		308	250	325	
D12-50×11	2357	1944	803	1423	1310	823	455		930	349			654	524	604	474	385		308	250	325	
D12-50×12	2495	2081	871	1491	1370	851	530		1000	368			368	524	604	474	410		330	280	370	

size model	h1	h2	h3	e	K	G	F	n	d	d1	进口法兰尺寸 Imported flange dimensions					出口法兰尺寸 Export flange size					电机型号 Motor model			
											D	D1	D2	Dg	n-φd	D	D1	D2	D3	Dg	n-φd	型号 model	功率 (KW)	
D12-50×3	20	40	254	4	15	214	315	4	20	M16×400	160	125	100	50	4-φ18	175	135	105	87	50	4-φ23	YB <sub>2</sub> 160L-2	18.5	
D12-50×4	22					200																YB <sub>2</sub> 180M-2	22	
D12-50×5	25					240																YB <sub>2</sub> 200L1-2	30	
D12-50×6						238																YB <sub>2</sub> 200L1-2	30	
D12-50×7	28				251	340	YB <sub>2</sub> 200L2-2															37		
D12-50×8					30	24	274															365	YB <sub>2</sub> 225M-2	45
D12-50×9							311															395	YB <sub>2</sub> 225M-2	45
D12-50×10	30				24	274	365															YB <sub>2</sub> 250M-2	55	
D12-50×11																						YB <sub>2</sub> 250M-2	55	
D12-50×12																						YB <sub>2</sub> 280S-2	75	

D25-30×(3~10) 多级离心泵外形安装尺寸表 (共同底座) multi-stage centrifugal pump external installation size table (common base) (mm)

Size model	L	L1	L2	L3	L4	L5	L6	L7	L8	L9	L10	B	B2	B3	B4	b1	b2	C	H	H1	h							
D25-30×3	1450	1110	230	845	760	432	0	275	605	330	315	210	530	460	460	210	265	218	160	170	225							
D25-30×4	1560	1219	295	910	850	478		320	650			254									250							
D25-30×5	1650	1297	360	975	880	510		332	670			241									250							
D25-30×6	1825	1432	425	1040	970	533		379	775			305									505	460	210	315	243	200	170	275
D25-30×7	1885	1497	490	1105	1000	538																						
D25-30×8	1950	1562	555	1170	1030	613																						
D25-30×9	2015	1627	620	1235	1080	663																						
D25-30×10	2150	1728	685	1300	1120	677		407	815			311									540	345	259	225	305			

size model	h1	h2	h3	e	K	G	F	n	d	d1	进口法兰尺寸 Imported flange dimensions					出口法兰尺寸 Export flange size					电机型号 Motor model		
											D	D1	D2	Dg	n-φd	D	D1	D2	D3	Dg	n-φd	型号 model	功率 (KW)
D25-30×3	22	35	210	5	15	165	250	4	30	M24×500	160	130	110	65	4-φ17.5	185	145	122	109	65	8-φ17.5	YB:160M2-2	15
D25-30×4																						YB:160L-2	18.5
D25-30×5																						24	180
D25-30×6	27	35	210	5	19	200	280	4	30	M24×500	160	130	110	65	4-φ17.5	185	145	122	109	65	8-φ17.5	YB:200L1-2	30
D25-30×7																						YB:200L2-2	37
D25-30×8																						YB:200L2-2	37
D25-30×9	28	35	210	5	19	210	305	4	30	M24×500	160	130	110	65	4-φ17.5	185	145	122	109	65	8-φ17.5	YB:225M-2	45
D25-30×10																						YB:225M-2	45

D25-50×(2~12) 多级离心泵外形安装尺寸表(共同底座) Multi-stage centrifugal pump shape installation size table (common base) (mm)

size model	L	L1	L2	L3	L4	L5	L6	L7	L8	L9	L10	H	H1	H2	H3	H4	H5	B1	B2	B3	n-d1
D25-50×2	1415	1096	-	743	167	811	600	4	191	110	544	200	315	200	225	40	-	464	464	254	4-Φ20
D25-50×3	1553	1209	-	806	200	879	670		259	145	557		315		250			469	469		4-Φ20
D25-50×4	1726	1355	-	884	235	947	775		327	178	569		315		275			509	509		4-Φ20
D25-50×5	1794	1423	-	918	268	1015	775		395	213	569		315		275			509	509		4-Φ20
D25-50×6	1902	1520	-	970	300	1083	815		463	252	585		340		305			464	549		4-Φ20
D25-50×7	2085	1689	-	1073	341	1151	930		531	281	634		365		325			474	604		4-Φ20
D25-50×8	2223	1829	615	615	300	1219	1000		599	393	656		395		360			480	664		6-Φ20
D25-50×9	2291	1897	632	632	320	1287	1000		667	441	656		395		360			480	664		6-Φ20
D25-50×10	2359	1965	660	660	330	1355	1000		735	499	656		395		360			480	664		6-Φ20
D25-50×11	2477	2084	700	700	345	1432	1050		803	552	656		395		360			480	664		6-Φ20
D25-50×12	2545	2152	725	725	365	1491	1050		871	600	656		395		360			480	664		6-Φ20

size model	泵脚尺寸 Pump foot size			电机脚尺寸 Motor foot size			进口法兰尺寸 Imported flange dimensions					出口法兰尺寸 Export flange size					电机型号 Motor model	功率 (kW)	
	L11	B4	n-d2	L12	B5	n-d3	D1	D2	D3	D4	n-d4	D5	D6	D7	D8	D9			n-d 5
D25-50×2	189	300	4-Φ18	210	254	4-Φ15	65	110	130	160	4-Φ14	65	109	130	160	200	8-Φ23	YB <sub>2</sub> 160M2-2	15
D25-50×3	257			241	279	4-Φ15												YB <sub>2</sub> 180M-2	22
D25-50×4	325			305	318	4-Φ19												YB <sub>2</sub> 200L1-2	30
D25-50×5	393			305	318	4-Φ19												YB <sub>2</sub> 200L2-2	37
D25-50×6	461			311	356	4-Φ19												YB <sub>2</sub> 225M-2	45
D25-50×7	529			349	406	4-Φ24												YB <sub>2</sub> 250M-2	55
D25-50×8	597			368	457	4-Φ24												YB <sub>2</sub> 280S-2	75
D25-50×9	665			368	457	4-Φ24												YB <sub>2</sub> 280S-2	75
D25-50×10	733			368	457	4-Φ24												YB <sub>2</sub> 280S-2	75
D25-50×11	801			419	457	4-Φ24												YB <sub>2</sub> 280M-2	90
D25-50×12	869			419	457	4-Φ24												YB <sub>2</sub> 280M-2	90

D46-30×(3~10) 多级离心泵外形安装尺寸表 (共同底座) multi-stage centrifugal pump external installation dimensions table (common base) (mm)

size model	L	L1	L2	L3	L4	L5	L <sub>6</sub>	L7	L8	L9	L1 <sub>0</sub>	B	B1	B2	B3	B4	b1	b2	C	H	H1	h				
												241	530			460			285	231			180			
D46-30×3	1520	1167	230	845	845	487	0	332	670	330	315	241	530	530			460			285	231	180			250	
D46-30×4	1690	1320	295	910	850	443		379	775			305	575				505			315	243	200			275	
D46-30×5	1775	1367	360	975	910	503		407	815			311	615				545	460	210	345	259	225			305	
D46-30×6	1860	1472	425	1040	925	528		458	930			349	664				594			385	308	250			325	
D46-30×7	1925	1523	490	1105	1010	580						535	1000		368	720			650			410	330	280		
D46-30×8	2105	1694	555	1170	1110	600																				
D46-30×9	2170	1759	620	1235	1140	630																				
D46-30×10	2305	1879	685	1300	1245	679																				

size model	h1	h2	h3	e	k	G	F	n	d	d1	进口法兰尺寸 Imported flange dimensions					出口法兰尺寸 Export flange size					电机型号 Motor model							
												D	D1	D2	Dg	n-φd	D	D1	D2	D3	Dg	n-φd	型号 model	功率 (KW)				
D46-30×3	24	35	210	3	15	192	260	4	3	0	M24×	19	15	12	8	0	4-	φ17.5	18	14	12	10	6	5	8-φ17.5	YB <sub>2</sub> 180M-2	22	
D46-30×4	27				19	210	280																			YB <sub>2</sub> 200L1-2	30	
D46-30×5					19	210	280																			YB <sub>2</sub> 200L2-2	37	
D46-30×6	28				24	220	305																			YB <sub>2</sub> 225M-2	45	
D46-30×7						220	305																			YB <sub>2</sub> 250M-2	55	
D46-30×8	33				235	330	250																			360	YB <sub>2</sub> 280S-2	75
D46-30×9					235	330																						
D46-30×10	38				250	360																						

D46-50×(2~12) 多级离心泵外形安装尺寸表 (共同底座) multi-stage centrifugal pump external installation dimensions table (common base) (mm)

size model	L	L1	L2	L3	L4	L5	L <sub>6</sub>	L7	L8	L9	L10	B	B1	B2	B3	B4	b1	b2	C	H	H1	h				
	D46-50×2	1656	1371	185	877	875	475.5	0	379	775	353	320.5	305	570	570	500	500	300	315	243	200	210	275			
D46-50×3	1716	245		937	311																			620	550	345
D46-50×4	1816	1415	305	997	925	505.5	407		815	349			670	600		385			308	250	325					
D46-50×5	1991	1571	365	1057	1020	535.5	458		930	368			720	570		650			500	300	410		330	280	210	360
D46-50×6	2121	1758	425	1117	1130	615.5	535		1000	419																
D46-50×7	2181		485	1177	1130	770.5	620		1240	820			750	576		356			315	550						
D46-50×8	2291	1869	545	1237	1180	665.5	586		1050																	
D46-50×9	2541		2046	605	1297	1130	770.5		620	1240			406	820		750			576	356	315		550			
D46-50×10	2601	665		1357	1130	770.5	620		1240																	
D46-50×11	2731	2222	725	1417	1480	880.5	670		1310	457			820	750		576			356	315	550					
D46-50×12	2791		785	1477	1480	880.5	670		1310																	

size model	h1	h2	h3	e	k	G	F	n	d	d1	进口法兰尺寸 Imported flange dimensions					出口法兰尺寸 Export flange size					电机型号 Motor model		
											D	D1	D2	Dg	n-φd	D	D1	D2	D3	Dg	n-φd	型号 model	功率 (KW)
D46-50×2	27	50	270	4	19	227	19	4	24	M20×400	190	150	128	80	4-φ17.5	215	170	133	120	80	8-φ22	YB <sub>2</sub> 200L1-2	30
D46-50×3																						YB <sub>2</sub> 200L2-2	37
D46-50×4	28	60	270	4	24	197	24	6	24	M20×400	190	150	128	80	4-φ17.5	215	170	133	120	80	8-φ22	YB <sub>2</sub> 225M-2	45
D46-50×5	33																					YB <sub>2</sub> 250M-2	55
D46-50×6	38	60	270	4	24	307	24	6	24	M20×400	190	150	128	80	4-φ17.5	215	170	133	120	80	8-φ22	YB <sub>2</sub> 280S-2	75
D46-50×7																						YB <sub>2</sub> 280M-2	90
D46-50×8	50	60	270	4	28	356	28	6	24	M20×400	190	150	128	80	4-φ17.5	215	170	133	120	80	8-φ22	YB <sub>2</sub> 315S-2	110
D46-50×9																						YB <sub>2</sub> 315M-2	133
D46-50×10	50	60	270	4	28	372	28	6	24	M20×400	190	150	128	80	4-φ17.5	215	170	133	120	80	8-φ22	YB <sub>2</sub> 315M-2	133
D46-50×11																						YB <sub>2</sub> 315M-2	133
D46-50×12	50	60	270	4	28	372	28	6	24	M20×400	190	150	128	80	4-φ17.5	215	170	133	120	80	8-φ22	YB <sub>2</sub> 315M-2	133

D85-45×(2~9) 多级离心泵外形安装尺寸表 multi-stage centrifugal pump shape installation size table

(mm)

size model	L	L1	L2	L3	L4	L5	L6	L7	L8	L9	L10	A	A1	B	B1	B2	B3	B4	b1	b2	C	H	H1	h
D85-45×2	1611	1235	203	832	840	425	0	379	775	326	309	-	-	305	590	590	520	520	250	315	243	200	210	275
D85-45×3	1840	1438	277	906	938	460		455	930					349	685		615			385	308	250		325
D85-45×4	1984	1567	351	980	1000	505		530	1000					368	750	680	410	330		280	360			
D85-45×5	2108	1691	425	1054	1072	545		586	1050					419		406	820	750		576	356	315		550
※ D85-45×6	2372	2046	499	1128	1330	773	665	620	1240	508	744	-	-	570	570	-	500	576	356	315	210	550		
※ D85-45×7	2516	780	573	1202	400	416	0	670	1310															
※ D85-45×8	2590	860	647	1276	480																			
※ D85-45×9	2664	930	721	1350	550																			

size model	h1	h2	h3	e	k	G	F	n	d	d1	进口法兰尺寸 Imported flange dimensions					出口法兰尺寸 Export flange size					电机型号 Motor model		
											D	D1	D2	Dg	n-φd	D	D1	D2	D3	Dg	n-φd	型号 model	功率 (KW)
D85-45×2	25	45	250	4	19	200	325	4	30	M24×500	210	170	148	100	4-φ17.5	235	190	158	149	100	8-φ22	YB <sub>2</sub> 200L2-2	37
D85-45×3	30				260	365	YB <sub>2</sub> 250M-2															55	
D85-45×4	35				24	302	400															YB <sub>2</sub> 280S-2	75
D85-45×5					319	YB <sub>2</sub> 280M-2	90																
D85-45×6	50	50	28	355	515	6	24	M24×400	YB <sub>2</sub> 315S-2	110													
※ D85-45×7				190	360	4	30	M24×500	YB <sub>2</sub> 315M-2	132													
※ D85-45×8																							
※ D85-45×9													YB <sub>2</sub> 315L1-2	160									

注：带“※”号的型号配单泵底座

Note: models with single pump base with "※".

D85-67×(2~9) 多级离心泵外形安装尺寸表 multi-stage centrifugal pump shape installation size table

(mm)

size model	L	L1	L2	L3	L4	L5	L6	L7	L8	L9	L <sub>0</sub>	A	A1	B	B1	B2	B3	B4	b1	b2	C	H	H1	h
D85-67×2	2081	1770	283	1146	1148	567	574	455	930	445	445	-	-	349	742	742	672	672	350	385	308	250	270	365
D85-67×3	2289	1936	371	1234	1296	658.5	648	581	1050	445	445	-	-	419	742	742	672	672		410	330	280	270	400
D85-67×4	2567	1936	459	1322	1296	688	648	609	1240	445	445	-	-	406	742	742	672	672		576	356	315	270	530
※ D85-67×5	2725	764	547	1410	484	476.5	0	720	1310	445	445	508	744	457	-	670	-	600		576	356	315	270	530
※ D85-67×6	2813	852	635	1498	572	476.5	0	720	1310	445	445	508	744	508	-	670	-	600		576	356	315	270	530
※ D85-67×7	2901	940	723	1586	660	476.5	0	720	1310	445	445	508	744	508	-	670	-	600		576	356	315	270	530
※ D85-67×8	3539	1028	811	1674	748	476.5	0	1280	1860	445	445	686	850	900	-	670	-	600		590	420	355	270	800
※ D85-67×9	3627	1116	899	1762	836	476.5	0	1330	1860	445	445	686	850	1000	-	670	-	600		590	420	355	270	800

size model	h1	h2	h3	e	k	G	F	n	d	d1	进口法兰尺寸 Imported flange dimensions					出口法兰尺寸 Export flange size					电机型号 Motor model				
											D	D1	D2	Dg	n-φd	D	D1	D2	D3	Dg	n-φd	型号 model	功率 (KW)		
D85-67×2	30	40			24	317	385	6																YB2250M-2	55
D85-67×3	35					320	395																	YB2280M-2	90
D85-67×4	45					320	430																	YB2315S-2	110
※ D85-67×5	45	50	350	5	28	140	420	4	30	M24×5 00	220	180	158	100	8-φ17.5	250	200	168	149	100	8-φ24			YB2315M-2	132
※ D85-67×6	45																							YB2315L1-2	160
※ D85-67×7	45																							YB2315L2-2	200
※ D85-67×8	34																							YB2-3553-2	220
※ D85-67×9	34																							YB2-3554-2	250

注：带“※”号的型号配单泵底座，220~250kW 电动机电压为高压 6000V,其余电动机电压均为低压 380V。

Note: The model with "※" is equipped with a pump base. The voltage of the 220~250kW motor is high voltage 6000V, and the voltage of the other motor is low voltage 380V.

D155-30×(2~10) 多级离心泵外形安装尺寸表 multi-stage centrifugal pump shape installation size table

( mm )

size model	L	L1	L2	L3	L4	L5	L6	L7	L8	L9	L1 0	A	A1	B	B1	B2	B3	B4	b1	b2	C	H	H1	h
D85-67×2	1980	1523	310	1131	1018	570	0	407	845	430	455	-	-	311	675	675	605	605	350	345	289	225	280	305
D85-67×3	2300	1770	425	1246	1148	630	574	535	1050					368	742	742	672	672		410	330	280		360
D85-67×4	2415	1936	540	1361	1296	730	648	586	1050					419	830	680	750	600		576	386	315		550
D85-67×5	2750	2469	655	1476	1700	1055	850	620	1270					406	830	680	750	600						
※ D85-67×6	2935	1055	770	1591	775	415	0	670	1340					457	-	680	-	600						
※ D85-67×7	3050	1055	885	1706	775	472.5								508										
※ D85-67×8	3165	1400	1000	1821	1120	357.5																		
※ D85-67×9	3280	1400	1115	1936	1120	415																		
※ D85-67×10	3395	1400	1230	2051	1120	472.5																		

size model	h1	h2	h3	e	k	G	F	n	d	d1	进口法兰尺寸 Imported flange dimensions					出口法兰尺寸 Export flange size					电机型号 Motor model			
											D	D1	D2	Dg	n-φd	D	D1	D2	D3	Dg	n-φd	型号 model	功率 (KW)	
D85-67×2	33	50	350	4	24	255	400	4	30	M24×5 00	285	240	211	150	8-φ22	300	250	211	203	150	8-φ26	YB <sub>2</sub> 225M-4	45	
D85-67×3	38					317		6														YB <sub>2</sub> 280S-4	75	
D85-67×4						320																YB <sub>2</sub> 280M-4	90	
D85-67×5	50					434	481	YB <sub>2</sub> 315S-4														110		
※ D85-67×6						28	140	400														4	YB <sub>2</sub> 315M-4	132
※ D85-67×7																							YB <sub>2</sub> 315L1-4	160
※ D85-67×8																							YB <sub>2</sub> 315L2-4	200
※ D85-67×9																								
※ D85-67×10																								

注：带“※”号的型号配单泵底座。

Note: The model with "※" is equipped with pump base.

D155-67×(3~9) 多级离心泵外形安装尺寸表 (单泵底座) multi-stage centrifugal pump shape installation size table (single pump base) (mm)																							
size model	L	L1	L2	L3	L4	L5	L7	L8	L9	L10	A	A1	B	B2	B4	b1	b2	C	H	H1	k	h	h1
	D155-67×3	2549	588	371	1234	308	476.5	580	1310	445	445	508	744	457	670	600	350	576	356	315	270	28	550
D155-67×4	2637	676	459	1322	396	630		1310	508			744	508	576				356	315	550			
D155-67×5	3275	764	547	1410	484	1280		1860	686			850	900	590				420	355	800			
D155-67×6	3363	852	635	1498	572	1330		1860	686			850	1000	590				420	355	800		35	34
D155-67×7	3641	940	723	1586	660	1425		2050	750			900	900	590				485	400	830			
D155-67×8	3729	1028	811	1674	748	1425		2050	750			900	900	590				485	400	830			
D155-67×9	3847	1116	899	1762	836	1495		2080	750			1000	1000	590				485	400	830			

size model	h2	h3	e	G	F	n	D	d1	进口法兰尺寸 Imported flange dimensions					出口法兰尺寸 Export flange size					电机型号 Motor model		
									D	D1	D2	Dg	n-φd	D	D1	D2	D3	Dg	n-φd	型号 model	功率 (KW)
D155-67×3	50	350	5	140	420	4	30	M24×500	280	240	210	150	8-φ23	340	280	240	203	150	8-φ34	YB <sub>2</sub> 315M-4	132
D155-67×4																				YB <sub>2</sub> 315L2-4	200
D155-67×5																				YB2-3553-2	220
D155-67×6																				YB2-3555-2	280
D155-67×7																				YB2-4001-2	315
D155-67×8																				YB2-4002-2	355
D155-67×9																				YB2-4004-2	450

注：132~200kW 电动机电压为低压 380V，其余电动机电压均为高压 6000V。

Note: The voltage of 132~200kW motor is low voltage 380V, and the voltage of other motors is high voltage 6000V.

D280-43×(2~9) 多级离心泵外形安装尺寸表 multi-stage centrifugal pump shape installation size table (mm)																																																																																	
size model	L	L1	L2	L3	L4	L5	L6	L7	L8	L9	L10	A	A1	B	B1	B2	B3	B4	b1	b2	C	H	H1	h																																																									
	※ D280-43×2	2496	1840	373	1220	1248	707.5	624	620	1270	420	480	-	-	406	830	800	750	720	450	576	386	315	330	550																																																								
D280-43×3	2696	625	503	1350	310	537.5	-	670	1340	508			744	508	-	790	-	720	590							450	355	800																																																					
D280-43×4	2826	755	633	1480	440			670	1340	686			850	1000															750	900	900	1000	590	525	400	830																																													
D280-43×5	3576	885	763	1610	570			1360	1960	1250			2110	1000																							1375	2200	1000	590	525	400	830																																						
D280-43×6	3856	1015	893	1740	700			1375	2200																																			1375	2200	1000	1375	2200	1000	590	525	400	830																												
D280-43×7	3988	1145	1023	1872	830																																																	1375	2200	1375	2200	1000	1375	2200	1000	590	525	400	830																
D280-43×8	4118	1275	1153	2002	960																																																													1375	2200	1375	2200	1000	1375	2200	1000	590	525	400	830				
D280-43×9	4338	1405	1283	2132	1090																																																																									1375	2200	1375	2200

size model	h1	h2	h3	e	k	G	F	n	D	d1	进口法兰尺寸 Imported flange dimensions					出口法兰尺寸 Export flange size					电机型号 Motor model			
											D	D1	D2	Dg	n-φd	D	D1	D2	D3	Dg	n-φd	型号 model	功率 (KW)	
※ D280-43×2	50			6	28	434	495	6	30	M24×500	340	295	268	200	8-φ22	375	320	285	259	200	12-φ30	YB2315S-4	110	
D280-43×3						157.5	480	4														35	YB2315L1-4	160
D280-43×4																							YB2315L2-4	200
D280-43×5	34	50	400	6	35	157.5	480	4	30	M24×500	340	295	268	200	8-φ22	375	320	285	259	200	12-φ30	YB2-3554-4	250	
D280-43×6																						YB2-4001-4	315	
D280-43×7																						YB2-4002-4	355	
D280-43×8																						YB2-4003-4	400	
D280-43×9																						YB2-4004-4	450	

注：带“※”号的型号配单泵底座, 110~200kW 电动机电压为低压 380V,其余电动机电压均为高压 6000V.

Note: The model with "\*" number is equipped with a pump base. The voltage of the 110-200kW motor is low voltage 380V, and the voltage of the other motors is high voltage 6000V.

D280-65×(2~10) 多级离心泵外形安装尺寸表 (单泵底座) multi-stage centrifugal pump shape installation size table (single pump base) (mm)																							
size model	L	L1	L2	L3	L4	L5	L7	L8	L9	L10	A	A1	B	B1	B2	B3	B4	b1	b2	C	H	H1	h
	D280-65×2	2855	560	345	1508	180	712	780	1340	627	642	508	640	508	-	870	-	790	500	576	386	315	380
D280-65×3	3605	690	475	1638	310	1360		1960	686			850	1000	590						450	355	800	
D280-65×4	3885	820	605	1768	440	1275		2110	750			900	900	590						525	400	830	
D280-65×5	4015	950	735	1898	570	1375		2200					1000								450		
D280-65×6	4235	1080	865	2028	700				1640			2260	950	1130						1250	975	434	
D280-65×7	4425	1210	995	2158	830	1670		2320															
D280-65×8	4555	1340	1125	2288	960																		
D280-65×9	4745	1470	1255	2418	1090																		
D280-65×10	4875	1600	1385	2548	1220																		

size model	h1	h2	h3	e	k	G	F	n	D	d1	进口法兰尺寸 Imported flange dimensions					出口法兰尺寸 Export flange size					电机型号 Motor model		
											D	D1	D2	Dg	n-φd	D	D1	D2	D3	Dg	n-φd	型号 model	功率 (KW)
D280-65×2	45	50	500	7	28	190	530	4	35	M30×600	340	295	268	200	12-φ22	415	345	285	259	200	12-φ36	YB2315L1-4	160
D280-65×3	34				YB2-3554-4																	250	
D280-65×4					35																	YB2-4002-4	355
D280-65×5					YB2-4003-4																	400	
D280-65×6					YB2-4501-4																	500	
D280-65×7					YB560M1-4																	630	
D280-65×8					YB560M2-4																	710	
D280-65×9					YB630S1-4																	800	
D280-65×10																							

注：160kW 电动机电压为低压 380V，其余电动机电压均为高压 6000V。

Note: The voltage of 160kW motor is low voltage 380V, and the voltage of other motors is high voltage 6000V.

size model	L	L1	L2	L3	L4	L5	L7	L8	L9	L10	A	A1	B	B1	B2	B3	B4	b1	b2	C	H	H1	h
D300-65×2	2855	560	345	1508	180	712	780	1340	627	642	508	640	508	-	870	-	790	500	576	386	315	380	550
D300-65×3	3605	690	475	1638	310		1360	1960			686	850	1000						590	450	355		800
D300-65×4	3885	820	605	1768	440		1275	2110			750	900	900						590	525	400		830
D300-65×5	4105	950	735	1898	570		1375	2200					1000										
D300-65×6	4135	1080	865	2028	700		1500	2100			1120	1250	590						525	400	830		
D300-65×7	4425	1210	995	2158	830		1640	2260			950	1130	1250						975	434	560		590
D300-65×8	4555	1340	1125	2288	960																		
D300-65×9	4745	1470	1255	2418	1090		1670	2320			1060	1240	1250						1050	460	630		655
D300-65×10	4875	1600	1385	2548	1220																		

size model	h1	h2	h3	e	k	G	F	n	d	d1	进口法兰尺寸 Imported flange dimensions					出口法兰尺寸 Export flange size					电机型号 Motor model		
											D	D1	D2	Dg	n-φd	D	D1	D2	D3	Dg	n-φd	型号 model	功率 (KW)
D300-65×2	4 5	50	50 0	7	28	190	530	4	35	M30×6 00	34 0	29 5	26 8	20 0	12-φ22	41 5	34 5	28 5	25 9	20 0	12-φ36	YB2315L2 -4	200
D300-65×3	35				YB2-3555 -4																	280	
D300-65×4	35				YB2-4002 -4																	355	
D300-65×5	35				YB2-4004 -4																	450	
D300-65×6	35				YB560S2- 4																	560	
D300-65×7	35				YB560M1 -4																	630	
D300-65×8	35				YB560M2 -4																	710	
D300-65×9	35				YB630S1- 4																	800	
D300-65×10	35				YB630S2- 4																	900	

注：200kW 电动机电压为低压 380V，其余电动机电压均为高压 6000V。

Note: The voltage of 200kW motor is low voltage 380V, and the voltage of other motors is high voltage 6000V.

size model	L	L1	L2	L3	L4	L5	L7	L8	L9	L10	A	A1	B	B1	B2	B3	B4	b1	b2	C	H	H1	h
D360-60×3	3654	744	539	1687	364	712	1360	1960	627	642	686	850	1000	-	870	-	790	500	590	450	355	380	800
D360-60×4	3961	901	696	1844	521		1275	2110			750	900	900						590	525	400		830
D360-60×5	4208	1058	853	2001	678		1375	2200			1000	975	434						560	590			
D360-60×6	4265	1215	1010	2158	835		1500	2100			1120	1050	460						630	655			
D360-60×7	4582	1372	1167	2315	992		1640	2260			1250												
D360-60×8	4779	1529	1324	2472	1149																		
D360-60×9	4956	1686	1481	2629	1306		1670	2320			1060	1240	1250										
D360-60×10	5113	1843	1638	2786	1463																		

size model	h1	h2	h3	e	k	G	F	n	d	d1	进口法兰尺寸 Imported flange dimensions					出口法兰尺寸 Export flange size					电机型号 Motor model		
											D	D1	D2	Dg	n-φd	D	D1	D2	D3	Dg	n-φd	型号 model	功率 (KW)
D360-60×3	3 4	50	50 0	7	35	190	530	4	35	M30×6 00	34 0	29 5	26 8	20 0	12-φ22	41 5	34 5	28 5	25 9	20 0	12-φ36	YB2-355 5-4	280
D360-60×4																						YB2-400 3-4	400
D360-60×5																						YB2-400 4-4	450
D360-60×6																						YB560S2 -4	560
D360-60×7					YB560M 1-4																	630	
D360-60×8					YB630S1 -4																	800	
D360-60×9					YB630S2 -4																	900	
D360-60×10					YB630S2 -4																	900	

注：电动机电压均为 6000V.

Note: motor voltage are 6000V.

D420-95×(2~12) 多级离心泵外形安装尺寸表 (单泵底座) multi-stage centrifugal pump shape installation size table (single pump base) (mm)																							
size model	L	L1	L2	L3	L4	L5	L7	L8	L9	L10	A	A1	B	B1	B2	B3	B4	b1	b2	C	H	H1	h
	D420-95×2	4230	790	420	2113	410	933	1275	2110	928	873	750	900	900	-	1010	-	910	600	590	525	450	560
D420-95×3	4380	950	580	2273	570	1500		2100	1120					975						434	560	590	
D420-95×4	4700	1110	740	2433	730	1640		2260	1250					1050						460	630	655	
D420-95×5	4920	1270	900	2593	890	1670		2320	1250					1050						460	630	655	
D420-95×6	5310	1430	1060	2753	1050	1820		2550	1400					1050						460	630	655	
D420-95×7	5390	1590	1220	2963	1210	983	1700	2420	978	923	1120	1120	1400	-	1010	-	910	600	1105	530	710	560	720
D420-95×8	5550	1750	1380	3123	1370		1920	2650					1600						1350	530	800		800
D420-95×9	5940	1910	1540	3283	1530																		
D420-95×10	6100	2070	1700	3443	1690																		
D420-95×11	6270	2230	1860	3603	1850																		
D420-95×12	6430	2390	2020	3763	2010	1910	2660	1600	1250	1250	1600	1600											

size model	h1	h2	h3	e	k	G	F	n	d	d1	进口法兰尺寸 Imported flange dimensions					出口法兰尺寸 Export flange size					电机型号 Motor model		
											D	D1	D2	Dg	n-φd	D	D1	D2	D3	Dg	n-φd	型号 model	功率 (KW)
D420-95×2	34	70	600	7	35	190	710	4	42	M36 ×650	405	355	320	250	12-φ 26	515	430	345	312	250	12-φ42	YB2-4501-4	355
D420-95×3					YB560M2-4																	500	
D420-95×4					YB630S2-4																	710	
D420-95×5					YB630M2-4																	900	
D420-95×6					YB710S2-4																	1120	
D420-95×7	38	70	600	7	48	190	710	4	42	M36 ×650	405	355	320	250	12-φ 26	515	430	345	312	250	12-φ42	YB710M1-4	1250
D420-95×8																						YB710M2-4	1400
D420-95×9																						YB800S1-4	1600
D420-95×10																						YB800S2-4	1800
D420-95×11	45	70	600	7	48	190	710	4	42	M36 ×650	405	355	320	250	12-φ 26	515	430	345	312	250	12-φ42	YB800M1-4	2000
D420-95×12																						YB800M2-4	2240

注：电动机电压均为 10000V.

Note: The electromechanical voltage is 10000V.

size model	L	L1	L2	L3	L4	L5	L7	L8	L9	L10	A	A1	B	B1	B2	B3	B4	b1	b2	C	H	H1	h
	D450-60×2	3516	615	421	1549	235	689	1360	1960	591	629	686	850	1000	-	950	-	850	500	590	450	355	410
D450-60×3	3819	770	574	1702	388	1275		2110	750			900	900	590						525	400	830	
D450-60×4	4062	920	727	1855	541	1375		2200	1000			1120	1250	975						434	560	590	
D450-60×5	4115	1075	880	2008	694	1500		2100	1130			1250	1050	460						630	655		
D450-60×6	4428	1230	1033	2161	897	1640		2260	1250			1060	1240	1250						1400			
D450-60×7	4641	1380	1186	2314	1000	1670		2320	1250			1060	1240	1250						1400			
D450-60×8	4794	1535	1339	2467	1153	1820		2550	1250			1060	1240	1250						1400			
D450-60×9	5177	1685	1492	2620	1306	1820		2550	1250			1060	1240	1250						1400			
D450-60×10	5330	1840	1645	2773	1459	1820		2550	1250			1060	1240	1250						1400			

size model	h1	h2	h3	e	k	G	F	n	D	d1	进口法兰尺寸 Imported flange dimensions					出口法兰尺寸 Export flange size					电机型号 Motor model		
											D	D1	D2	Dg	n-φd	D	D1	D2	D3	Dg	n-φd	型号 model	功率 (KW)
D450-60×2	34	50	550	7	35	190	560	4	42	M3 6× 650	405	355	320	250	12-φ26	470	400	345	312	250	12-φ36	YB2-3554-4	250
D450-60×3						192																YB2-4002-4	355
D450-60×4						189																YB2-4004-4	450
D450-60×5						191																YB560S2-4	560
D450-60×6					42	193																YB560M1-4	630
D450-60×7						190																YB630S1-4	800
D450-60×8						192																YB630S2-4	900
D450-60×9						189																YB630M1-4	1000
D450-60×10						191																YB630M2-4	1120

D720-60×(2~10) 多级离心泵外形安装尺寸表 (单泵底座) multi-stage centrifugal pump shape installation size table (single pump base) (mm)																																										
size model	L	L1	L2	L3	L4	L5	L7	L8	L9	L10	A	A1	B	B1	B2	B3	B4	b1	b2	C	H	H1	h																			
	D720-60×2	3861	712	518.5	1744	412	679	1275	2110	607	642	750	900	900							590	525	400		830																	
D720-60×3	4036	897	703.5	1929	597	1500		2100	950			1130	1120	975							434	560	590		525	400	590	525	400	590	525	400	590									
D720-60×4	4381	1082	888.5	2114	782	1640		2260	1670			2320	1250	1060							1240	1250	1050		460	630	520	655	1050	460	630	520	655									
D720-60×5	4626	1267	1073.5	2299	967	1820		2550	1700			2420	1400	1120							1340	1400	1105		500	710	720	1105	500	710	720	1105	500	710	720							
D720-60×6	5041	1452	1258.5	2484	1152	729	1700	2420	657	692	1120	1340	1600																													
D720-60×7	5146	1637	1443.5	2719	1337		1920	2650																	1920	2650	1600	1920	2650	1600	1920	2650	1600	1920	2650	1600	1920	2650	1600	1920	2650	1600
D720-60×8	5331	1882	1628.5	2904	1522		1920	2650																	1920	2650	1600	1920	2650	1600	1920	2650	1600	1920	2650	1600	1920	2650	1600	1920	2650	1600
D720-60×9	5746	2007	1813.5	3089	1707		1920	2650																	1920	2650	1600	1920	2650	1600	1920	2650	1600	1920	2650	1600	1920	2650	1600	1920	2650	1600
D720-60×10	5931	2192	1998.5	3274	1892																																					

size model	h1	h2	h3	e	k	G	F	n	d	d1	进口法兰尺寸 Imported flange dimensions					出口法兰尺寸 Export flange size					电机型号 Motor model				
											D	D1	D2	Dg	n-φd	D	D1	D2	D3	Dg	n-φd	型号 model	功率 (KW)		
	D720-60×2	3 4	65	62 9	7	35	15 0	700	4	42	M36×6 50	46 0	41 0	37 0	30 0	12-φ26	53 0	46 0	40 9	36 3	30 0	12-φ36	YB2-4002 -4	355	
D720-60×3	42					YB560S2- 4																	560		
D720-60×4	42					YB560M2 -4																	710		
D720-60×5	42					YB630S2- 4																	900		
D720-60×6	3 8	65	62 9	7	42	15 0	700	4	42	M36×6 50	46 0	41 0	37 0	30 0	12-φ26	53 0	46 0	40 9	36 3	30 0	12-φ36	YB630M1 -4	1000		
D720-60×7					48																	YB710S1- 4	1250		
D720-60×8					48																	YB710S2- 4	1400		
D720-60×9					48																	YB710M1 -4	1600		
D720-60×10																									

注：1、电动机电压均为 6000V。

Note: 1. The voltage of the motor is 6000V.