

INVERTER GENERATOR USER'S MANUAL

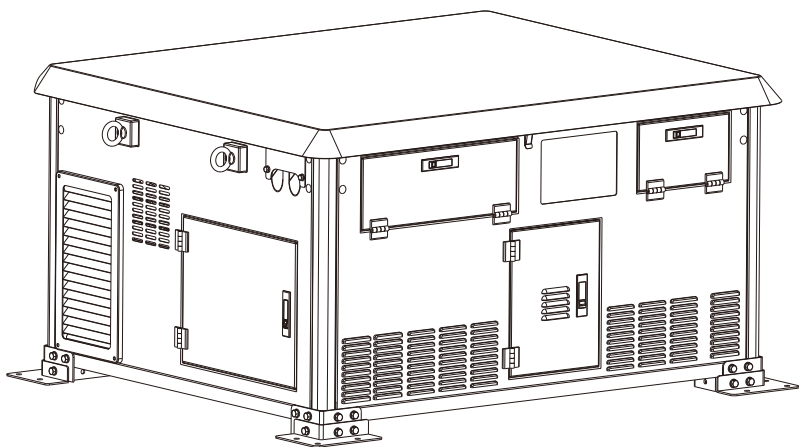

GM14000i-HSB

GASOLINE INVERTER GENERATOR



14000 STARTING WATTS
13000 RUNNING WATTS



12500 STARTING WATTS
11500 RUNNING WATTS



11000 STARTING WATTS
10000 RUNNING WATTS



WARNING: SAVE THIS MANUAL FOR FUTURE REFERENCE



This manual contains important information regarding safety. Operation, maintenance and storage of this product. Before use, read carefully and understand all cautions, warnings, instructions and product labels. Failure to do so could result in serious personal injury and/or property damage.

Thank you very much for choosing generator set product manufactured by our Company!

This Manual will instruct you how to operate and use the generator set safely and properly. Please be sure to read it carefully before using.

All technical data and diagrammatic presentations in this User's Manual are consistent with the latest product at the time of publication.

Due to the revision and other changes, contents of this Manual may be slightly different from actual situation. The Company is entitled to revise it at any time, and the revised version will be developed without prior notice, please understand that. The copyright of this User's Manual belongs to the Company, and this Manual is not allowed to be reproduced without written consent of the Company, violators must be prosecuted.

This Manual is a permanent part of the generator set. If the generator set is resold, the Manual will be resold together with the generator set.

TABLE OF CONTENTS

SAFETY	2
NAMES OF COMPONENTS	6
ASSEMBLY(FIXED).....	8
ASSEMBLY(WHEEL).....	9
CONTROL FUNCTIONS.....	10
PREPARATIONS	14
OPERATION	18
USING THE GENERATOR	24
SERVICE AND MAINTENANCE	26
STORAGE AND TRANSPORT	30
TROUBLESHOOTING	3 1
TECHNICAL PARAMETERS	33

SAFETY

Personal and property safeties of you and others are very vital. Please read the Safety Warning in the User's Manual and the decals of the generator set carefully.

The Safety Warning can alert you to those potential hazards that could harm you and others. In front of each Safety Warning, there is one of four words "DANGER", "WARNING", "ATTENTION", and "CAREFUL". Details are as follows:

⚠ DANGER

Failure to follow the instruction will result in being in peril of your life or extremely serious injury.

⚠ WARNING

Failure to follow the instruction will result in being in peril of your life or very serious injury.

⚠ CAREFUL

Failure to follow the instruction will result in minor injury.



ATTENTION

Failure to follow the instruction will result in the damage to your generator set and other properties.

SAFETY PRECAUTIONS

⚠ DANGER

Using a generator indoors **CAN KILL YOU IN MINUTES.**
Generator exhaust contains carbon monoxide. This is a poison you cannot see or smell.

 <p>NEVER use inside a home or garage, EVEN IF doors and windows are open.</p>	 <p>Only use OUTSIDE and far away from windows, doors, and vents.</p>
--	---

⚠ WARNING

Engine exhaust contains carbon monoxide, a poisonous gas that could kill you in minutes. You **CANNOT** smell it, see it, or taste it. Even if you do not smell exhaust fumes, you could still be exposed to carbon monoxide gas.

- Operate this product **ONLY** outside far away from windows, doors and vents to reduce the risk of carbon monoxide gas from accumulating and potentially being drawn towards occupied spaces.
- Install battery-operated carbon monoxide alarms or plug-in carbon monoxide alarms with battery back-up according to the manufacturer's instructions. Smoke alarms cannot detect carbon monoxide gas.
- **DO NOT** run this product inside homes, garages, basements, crawlspaces, sheds, or other partially-enclosed spaces even if using fans or opening doors and windows for ventilation. Carbon monoxide can quickly build up in these spaces and can linger for hours, even after this product has shut off.
- **ALWAYS** place this product downwind and point the engine exhaust away from occupied spaces. If you start to feel sick, dizzy, or weak while using this product, shut it off and get to fresh air **RIGHT AWAY**. See a doctor. You may have carbon monoxide poisoning.
- If you start to feel sick, dizzy or weak while using the portable generator, you may have carbon monoxide poisoning. Get out side to fresh air immediately and emergency medical assistance.. Very high levels of CO can rapidly cause victims to lose consciousness before they can rescue themselves. **DO NOT** attempt to shut off the generator before moving to fresh air. Entering an enclosed space where a generator is or has been running may put you at greater risk of CO poisoning.

SAFETY

CORRECT USAGE

Example location to reduce risk of carbon monoxide poisoning

- ONLY use outside and downwind, far away from windows, doors and vents.
- Direct exhaust **AWAY** from windows, doors, and vents.

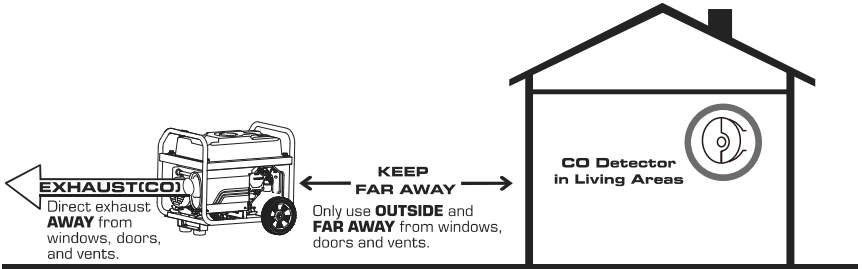

INCORRECT USAGE

Do not operate in any of the following locations:

- Near any door, window or vent
- Garage
- Basement
- Crawl Space
- Living Area
- Attic
- Entry Way
- Porch
- Mudroom

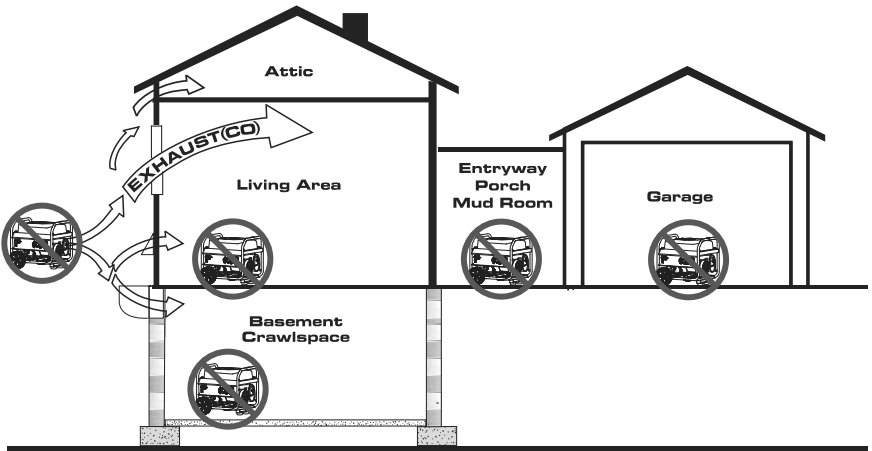

SAFETY

BEFORE USING THE GENERATOR

- In order to operate the generator correctly, be familiar with the operation of the various components and master the method of shutting down the generator quickly.
- Without proper instructions and directions, no one is allowed to operate this machine. It is strictly prohibited for newborns, young children, the elderly, people with disabilities, and other vulnerable groups to operate. Otherwise, it will become a cause of serious accidents and machine damage.
- Never use the generator to power medical support equipment.
- Please never modify the generator.
- Please do not use in rain or in areas with water. There is a risk of electric shock when using generators and connected appliances that have been soaked in rain or water, or when operating with wet hands.
- Please never connect wires from the power company. It can cause malfunctions in the machine and connected electrical equipment, becoming the cause of fire or personal accidents.
- The use of generators has laws and regulations, please comply with labor safety and health regulations, fire protection laws, electrical industry laws, etc.
- Please do not connect parallel operation terminals except for dedicated wires. There is a risk of electric shock.

WHEN ADDING OR DRAINING GASOLINE

Turn the generator engine OFF and let it cool for at least 2 minutes before removing the fuel cap. Loosen the cap slowly to relieve pressure in the tank.

- Fill or drain fuel tank outdoors.
- DO NOT overfill the tank. Allow space for fuel expansion.
- If fuel spills, wipe it up and let the area dry before starting the engine.
- Keep fuel away from sparks, open flames, heat, and other ignition sources.

- Check fuel lines, tank, cap, and fittings frequently for cracks or leaks; replace if necessary.
- DO NOT light a cigarette or smoke anything.

WHEN STARTING EQUIPMENT

- Ensure spark plug, muffler, fuel cap, and air cleaner are in place.
- DO NOT crank engine with spark plug removed.

WHEN OPERATING EQUIPMENT

- DO NOT operate this product inside any building, carport, porch, mobile enclosure, marine applications, or shed.
- DO NOT tip engine or equipment at an angle that causes fuel to spill.
- DO NOT stop the engine by moving the choke control the to "Start" position.
- DO NOT exceed the generator's wattage capacity.
- Start the generator and the let engine stabilize before connecting electrical loads.
- Connect electrical loads in the OFF position, then turn ON for operation.
- Turn electrical loads OFF and disconnect from the generator before stopping the generator.

ATTENTION

Improper treatment of the generator could damage it and shorten its life.

- Use generator only for intended applications.
- If you have questions about intended use, ask a dealer.
- Operate generator only on solid, level surfaces.
- DO NOT expose the generator to excessive moisture, dust, dirt, or corrosive vapors.
- DO NOT insert any objects through cooling slots.
- If connected devices overheat, turn them off and disconnect them from the generator.

SAFETY

PARALLEL KIT PRECAUTIONS

To prevent serious injury, death and damage to generators and/or equipment due to electric shock and fire:

- Follow Parallel Kit instructions provided with Kit for connection and use of a Parallel Kit.
- Only connect two identical Inverter Generators together using a Parallel Kit.
- Connect Parallel Kit only to terminals marked "Parallel Outlets" on the front of the Generator.
- Do not remove or connect a Parallel Kit while the Generator is running.
- Do not use a Parallel Kit that is attached to only one Generator.

SAFETY PRECAUTIONS FOR GASOLINE AND GASOLINE VAPOR

- Fire and explosion hazard. Gasoline is highly explosive and flammable and can cause severe burns or death.
- Fire and Burn Hazard. NEVER loosen or remove the fuel cap while the generator is running. Turn the unit off and allow it to cool for at least five minutes before adding gasoline. Loosen the fuel cap slowly.
- In case of a gasoline fire, do not attempt to extinguish the flame unless the engine/fuel control switch is in the OFF position. Introducing an extinguisher to a generator with an open fuel valve could create an explosion hazard.

LIQUID PETROLEUM GAS (LPG/PROPANE)

Fire and explosion hazard. Never use a gas container, LPG/propane hose, propane cylinder or any other fuel item that appears to be damaged. If there is a strong smell of propane while operating the generator, fully close the propane cylinder valve immediately. Once the propane is off, use soapy water to check for leaks on the hose and connections on the tank valve and the generator. Do not smoke or light a cigarette

or check for leaks using any open flame source such as a match or lighter. If a leak is found, contact a qualified technician to inspect and repair the LPG/ propane system before using the generator.

NATURAL GAS (NG)

Fire and explosion hazard. Never use a natural gas supply line, natural gas hose, or any other fuel item that appears to be damaged. If there is a strong smell of natural gas while operating the generator, close off all gas sources immediately. Once the natural gas is off, use soapy water to check for leaks on the hose and connections on the branch supply and the generator. Do not smoke or light a cigarette or check for leaks using any open flame source such as a match or lighter. If a leak is found, contact a qualified plumber to inspect and repair the natural gas system before using the generator.

NAMES OF COMPONENTS

Before operating your generator, you must read and understand the manual and familiarize yourself with the safe operation practices.

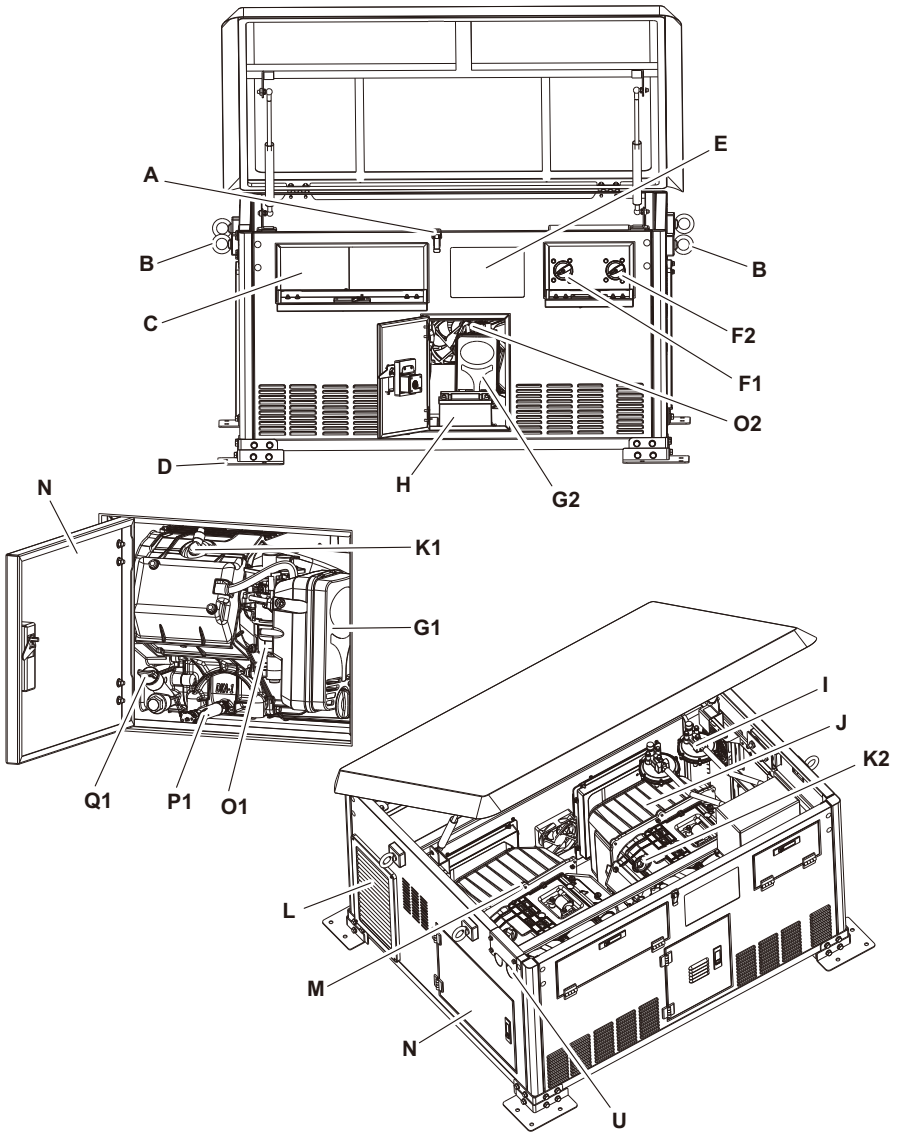

STATEMENT: The illustrations used in this manual are intended as representative reference views only.

NAMES OF COMPONENTS

Before operating your generator, you must read and understand the manual and familiarize yourself with the safe operation practices.

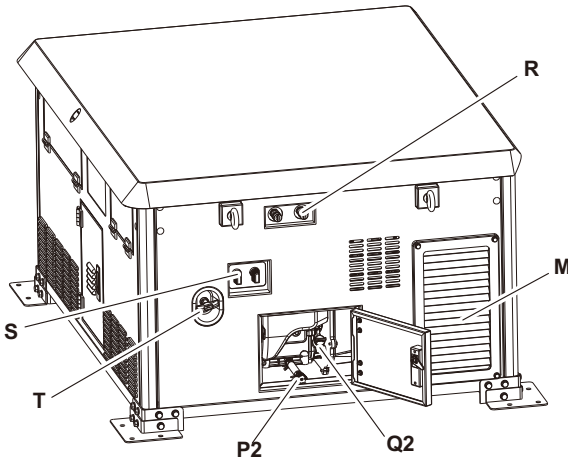

- | | |
|--|--|
| A. Lock With Cover | L. Exhaust Port |
| B. Lifting Ring | M. Engine No.1 |
| C. Control Panel | N. Access Door(Engine No.1) |
| D. Install Feet | O1. Carburetor(Engine No.1) |
| E. Digital Display Table | O2. Carburetor(Engine No.2) |
| F1. Fuel Source Switch(Engine No.1) | P1. Oil Drain Hose(Engine No.1) |
| F2. Fuel Source Switch(Engine No.2) | P2. Oil Drain Hose(Engine No.2) |
| G1. Air Filter(Engine No.1) | Q1. Oil Dipstick(Engine No.1) |
| G2. Air Filter(Engine No.2) | Q2. Oil Dipstick(Engine No.2) |
| H. Battery | R. LPG/NG Inlet |
| I. Fuel regulator | S. Fuel Inlet |
| J. Engine No.2 | T. Recoil Start Handle |
| K1. Spark Plug(Engine No.1) | U. Load Outlet Port |
| K2. Spark Plug(Engine No.2) | |

STATEMENT: The illustrations used in this manual are intended as representative reference views only.

ASSEMBLY(FIXED)

INSTALL FEET

ATTENTION

This product requires assembly. Do not attempt to operate this product if any items in the INCLUDED LIST are already assembled when you remove the carton contents. These items are not assembled by the manufacturer and should require customer assembly. Using an improperly assembled product can be hazardous and could result in serious personal injury.

Align the mounting holes of the feet with the mounting holes at the bottom of the generator and secure them with bolts. *(If there are other installation methods, you don't need to install this foot)*

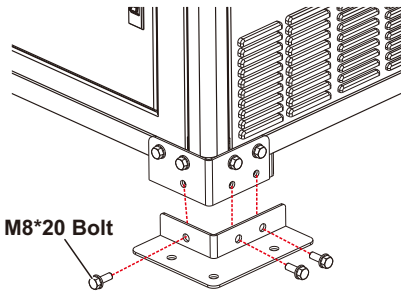

Verify all shrubs or tall grasses within 5 ft (0.91 m) of intake and discharge louvers on the sides of the enclosure have been removed. Install generator on high ground where water levels will not rise and endanger it. This unit must not operate in or be subjected to standing water. Verify all potential water sources such as water sprinklers, roof run-off, rain gutter downspouts, and sump pump discharges are directed away from unit.

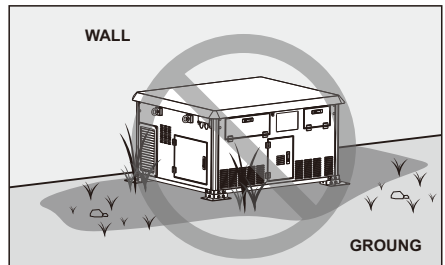
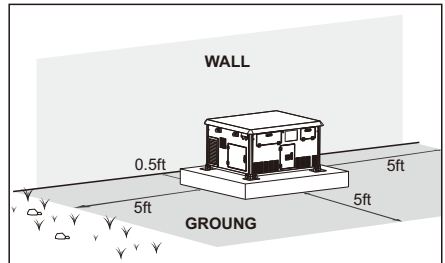

SITE PREP VERIFICATION

⚠ DANGER

Automatic start-up. Disconnect utility power and render unit inoperable before working on unit. Failure to do so will result in death or serious injury.

Generator must be installed to allow unimpeded airflow into and out of generator. Mechanical and gravity outdoor air intake openings for air distribution and supply systems must be located not less than 10 ft (3.05 m) horizontally from generator enclosure. See Section 401.4 in the ICC Mechanical Code for additional information.

FIXED GENERATOR

ATTENTION

All components that need to be installed before using this product must be installed in place and regularly checked for loose connections at the installation points.

Secure the generator feet to the platform using bolts. Alternative fastening methods are acceptable, provided they ensure the generator remains completely immobile during operation. **SAFETY NOTE: All fasteners must be properly rated and installed to prevent hazardous movement or vibration.**

ASSEMBLY(WHEEL)

INSTALL WHEEL

ATTENTION

This product requires assembly. Do not attempt to operate this product if any items in the INCLUDED LIST are already assembled when you remove the carton contents. These items are not assembled by the manufacturer and should require customer assembly. Using an improperly assembled product can be hazardous and could result in serious personal injury.

The operation steps are as follows:

- ① Remove the original mounting base from the generator;
- ② Assemble the wheels with the mounting base;
- ③ Reinstall the assembled wheel - attached base back to the generator.

See the figure for details.

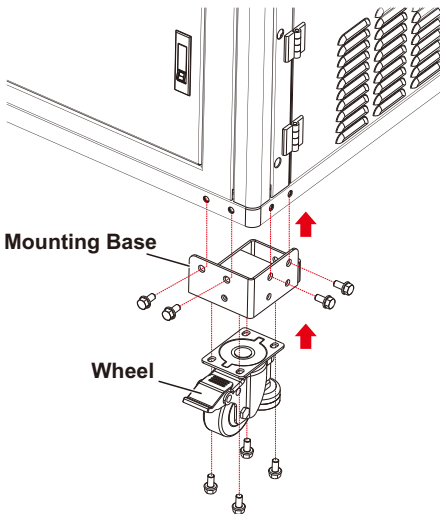

After the wheels are installed, follow these steps for operation:

For moving the generator: Use a wrench to turn the adjustment nut on the support leg counterclockwise to lift the support leg off the ground, then unlock the wheel lock to move the unit.

For fixed placement or starting the generator: First lock the wheel lock tightly, then use a wrench to turn the adjustment nut on the support leg clockwise. Lower the support leg until it touches the ground and the wheels are completely off the ground.

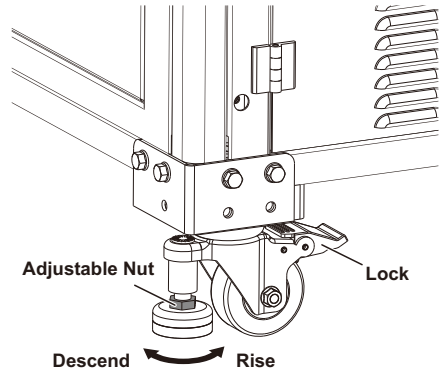

CONTROL FUNCTIONS

CONTROL PANEL 1

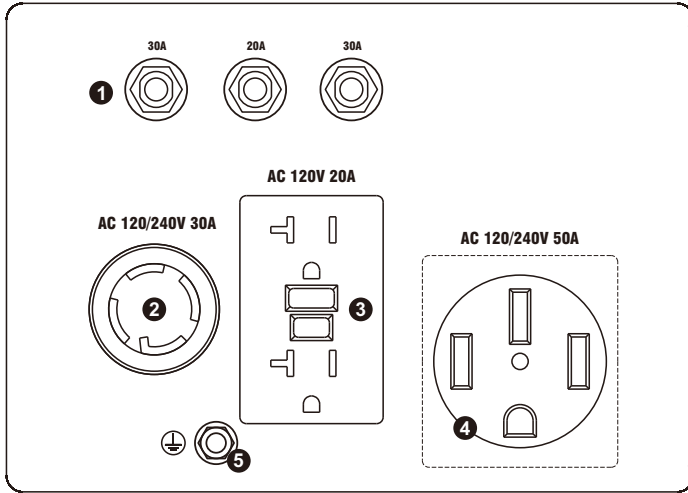

- ① **Circuit Breakers:** The circuit breakers protect individual circuits from electrical overload.
- ② **120/240V AC 30A L14-30R Outlet:** The outlet is capable of carrying a maximum of 30 amps.
- ③ **120V AC 20A 5-20R Outlet:** The outlet is capable of carrying a maximum of 20 amps.
- ④ **120/240V AC 50A 14-50R Outlet:** Receptacle can supply a maximum of 50 Amps.
- ⑤ **Ground Terminal:** The ground terminal is used to externally ground the inverter.

CONTROL FUNCTIONS

CONTROL PANEL 2

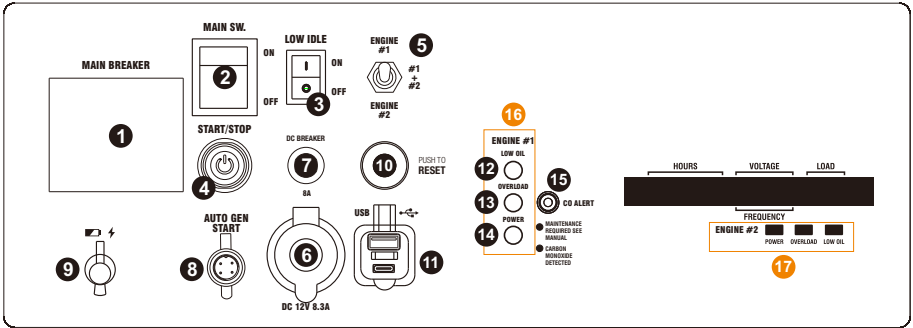

- ① **Main Circuit Breaker:** The main circuit breaker controls total output of all outlets to protect the generator from overload or short circuit.
- ② **Main Switch:** Manage battery power and shutdown.
- ③ **Low Idle:** When turned to the ON position, the engine will sense the load needed and run at a slower RPM to save fuel.
- ④ **START/STOP Switch:** Press this button, the engine can start and stop.
- ⑤ **Engine Mode:** Select the engine start/run mode.
- ⑥ **DC Cigarette Lighter Outlet:** 12V DC 8.3A.
- ⑦ **DC Protector:** If the generator is overload, the DC protector will trip to block current.
- ⑧ **AUTO GEN START:** The communication interface for automatically starting and stopping the generator. Used to connect equipment with automatic start stop function. *(Automatic control equipment is sold separately)*
- ⑨ **Battery Charging Port:** Charge the generator battery.
- ⑩ **Reset:** If the inverter is overloaded, the reset breaker will trip. The engine will continue to run, but there will be no output from the inverter. Unplug the devices and reduce the load. Push in the reset breaker to reset it.
- ⑪ **USB Duplex:** 5V DC, type-A and type-C connectors.
- ⑫ **Low Oil Alarm:** Indicates low oil level.
- ⑬ **Overload Alarm:** Indicates that the inverter is overloaded.
- ⑭ **Power Indicator:** Indicates the inverter is ready to be used.
- ⑮ **CO Alarm:** Flashing red light: dangerous levels of carbon monoxide gas have built up leave immediately until area has aired out. Move generator to well-ventilated area before operation. Flashing yellow light: carbon monoxide sensor malfunction. Sensor needs service.
- ⑯ Engine No.1 running status indicator light group.
- ⑰ Engine No.2 running status indicator light group.

CONTROL FUNCTIONS

Note: The product you purchased may not have these configurations, please refer to the actual product.

Fuel Source

OFF - Turn off fuel supply

Propane(LPG) - Using propane as fuel.

Methane(NG) - Using methane as fuel.

Gasoline - Using gasoline as fuel.

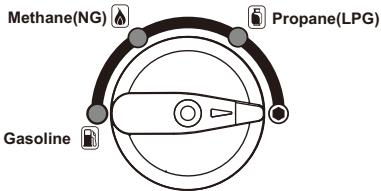

FUEL SOURCE

Main Switch (Engine Switch)

OFF - Ignition circuit is off, the engine stopped running.

ON - Ignition circuit is on, the start the engine.

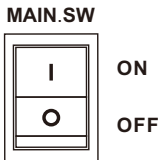

Engine Mode

#1 - Only start Engine No. 1.

#2 - Only start Engine No. 2.

#1+#2 - Two engines start simultaneously.

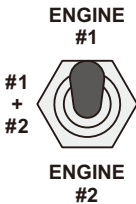

Remote Control

OFF - Generator outage.

ON - Generator operation.

Remote Control Pairing:

1. Long press the start button for more than 5 seconds until the button red indicator is on;
2. Press any key on the remote control;
3. The red indicator of the start button will blink two or three times and then turns off, Remote start pairing is successful.

Tip: The remote control delivered with the generator has been paired successfully.

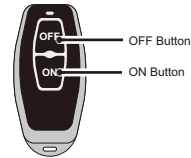

Energy-Saving Switch (LOW IDLE)

LOW IDLE

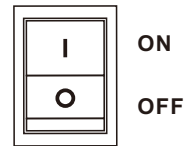

1) "ON"

When energy saving switch is switched to "ON" position engine speed is reduced when the generator is under light load. This feature will reduce fuel consumption and noise.

2) "OFF"

When the energy saving switch is set to the "OFF" position, the engine will run at rated speed, regardless of connected load.

CONTROL FUNCTIONS

Battery Charging

Keep the generator battery fully charged and ready to use to avoid the need to use the recoil starter to start the generator manually.

The battery shipped with the generator has been partially charged. A battery may lose some charge when not in use for prolonged periods of time.

- Once the generator is started, it will immediately charge the battery.
- When the generator is not running, the attached charger can charge the battery.
- Charge in a dry place.
- The charging time should not exceed 30-40 minutes.

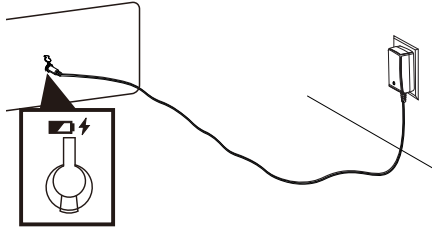

Digital Display Center

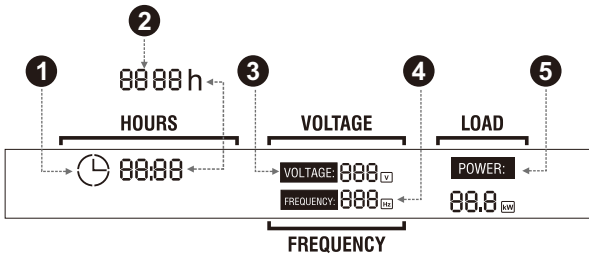

- ① 88:88 : Represents single run time, goes from 0 at each startup.
- ② 8888 h : Represents total operation time of the generator. (Tip: The total operation time shall start to accumulate after the generator runs for one hour. It will not be displayed when the generator runs for less than one hour. The total operation time shall be accumulated by hours.) The two factors ① and ② are displayed alternately every 8 seconds.
- ③ **VOLTAGE**: Voltage display: 120V and 240V switch every 16 seconds.
- ④ **FREQUENCY**: Frequency display.
- ⑤ **LOAD**: Load power display.

PREPARATIONS

ADD ENGINE OIL

⚠ WARNING

No oil is filled into this generator when being delivered. Do not start up the generator without filing sufficient oil.

ATTENTION

Your generator was functionally tested in the factory and may contain minimum residual oil. Additional oil is required to operate the unit. Do not overfill.

ATTENTION

The recommended oil type for typical use is 10W-30 automotive oil. However, using the listed conventional oils shown in the "Recommended Engine Oil Type" chart may be used for typical use including the first 5 hours of the break-in run time period of the engine. If running generator in extreme temperatures, refer to the "Recommended Engine Oil Type" chart.

Recommended Engine Oil Type								
		10W-30						
	5W-30			10W-40				
	5W-30 Full Synthetic							
°F	-20	0	20	40	60	80	100	120
°C	-28.9	-17.8	-6.7	4.4	15.6	26.7	37.8	48.9
Ambient Temperature								

1. Confirm that the generator is stopped and powered off.
2. Open the oil access door.
3. Remove oil dipstick to add oil.
4. Using a funnel, as needed, add the appropriate type of oil until the oil level is at the proper level. SAE 10W-30 oil is recommended for general use. DO NOT OVERFILL. Replace oil dipstick.

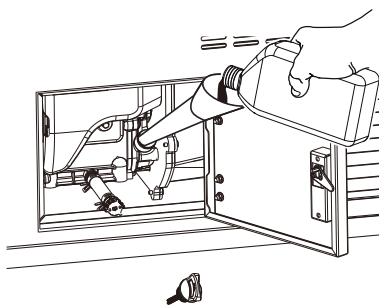

Note: Both Engine No. 1 and Engine No. 2 need to have engine oil added.

5. Check engine oil level daily and add as needed.

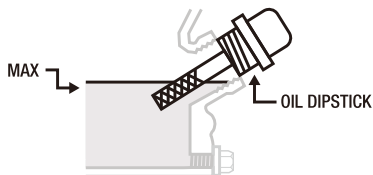

ATTENTION

Once the oil has been added, a visual check should show oil about 1-2 threads from running out of the fill hole. When using the dipstick to check the oil level, DO NOT screw in the dipstick while checking.

⚠ CAREFUL

This engine is equipped with a low oil shut-off and will stop when the oil level in the crankcase falls below a critical level.

ADD GASOLINE

⚠ WARNING



TO PREVENT SERIOUS INJURY FROM FIRE: Fill the gasoline tank in a well-ventilated area away from ignition sources. If the engine is hot from use, shut the engine off and wait for it to cool before adding gasoline. Do not smoke.

PREPARATIONS

1. Confirm that the generator is stopped and powered off.
2. Connect fuel tank to generator. (Fuel tank sold separately)

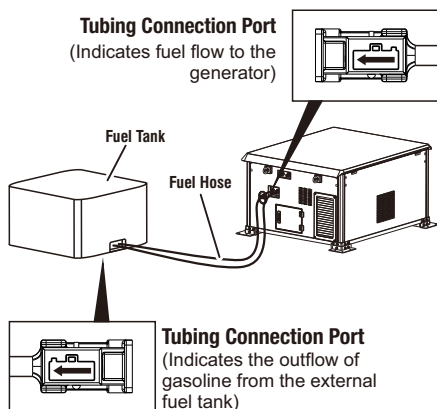

Note: Both Engine No. 1 and Engine No. 2 need to be connected to gasoline.

Note: The fuel tank must be placed higher than the engine to facilitate the normal operation of the engine.

3. Add an appropriate amount of gasoline to the fuel tank.

⚠ DANGER

Do not place the fuel tank or fuel hose in the position of the generator exhaust port, as the temperature at the exhaust port will be relatively high, and placing it in this position will be very dangerous.

⚠ DANGER

Do not overfill the gasoline the tank. Overfilling can result in a fire, explosion, or death.

⚠ WARNING

Gasoline can expand. Do not fill the gasoline tank to the top. Leave a minimum of 1.5 inches open space. Gasoline fumes are highly flammable. Do not fill the tank near an open flame. Always check for gasoline spills.

- To ensure the generator runs smoothly, only fresh, unleaded gasoline is used.
- Never use an oil/gasoline mixture. Never use old gasoline.
- Avoid getting dirt or water in the gasoline tank.
- Gasoline can age in the tank and make it hard to start the generator in the future.
- Never store generator for extended periods of time with gasoline in the tank.

CONNECTING AN LPG TANK

ATTENTION

- Confirm that the re-qualification date on the tank has not expired.
- All new propane tanks must be purged of air and moisture prior to filling. Used propane tanks that have not been plugged or kept closed must also be purged. The purging process should be done by a propane tank supplier (propane tanks from an exchange supplier should have been purged and filled properly).
- ALWAYS position the propane tank so the connection between the valve and the gas inlet will not cause sharp bends or kinks in the hose.

⚠ DANGER

Explosion hazard. DO NOT start generator if you smell propane. ALWAYS fully close the propane tank valve and disconnect the LPG hose from the generator when not in use.

1. Turn the generator OFF and place on a flat surface in a well ventilated area.
2. Verify that the LPG tank valve is in the fully closed position.

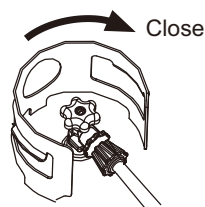

PREPARATIONS

3. Remove the cover on the generator propane inlet.
4. Tighten the LPG hose to the propane/methane inlet of the generator.

IMPORTANT: DO NOT use thread seal tape or any other type of sealant to seal the LPG hose connection.

5. Push back the quick connector collet of the LPG hose, insert it into the generator propane/methane inlet, loosen the quick connector sleeve, and make the sleeve clamp the propane/methane inlet.

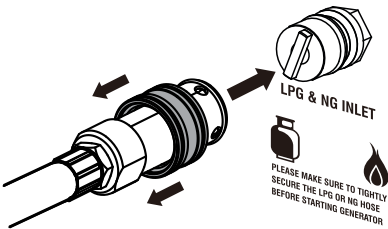

6. Remove the safety plug or cap from the LPG tank valve and attach the other end of the hose to the LPG connector on the tank. Hand-tighten.

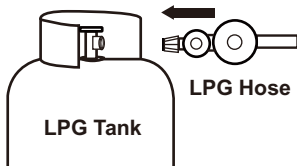

7. Turn the LPG tank valve to the fully open position. Check all connections for leaks by wetting the fittings with a solution of soap and water. Bubbles which appear or bubbles which grow indicate that a leak exists. If a leak exists at a fitting, turn the LPG tank valve to the fully closed position and tighten the fitting. Open the LPG tank valve and recheck the fitting with the soap and water solution.

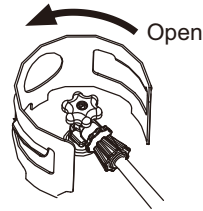

CONNECT THE NATURAL GAS (NG) SUPPLY LINE

⚠ DANGER

Fire and explosion hazard. Never connect or disconnect the natural gas hose while the engine is running. Do not smoke or create sparks while handling natural gas. Always turn the engine off and allow the generator to cool for at least five minutes before connecting to natural gas.

⚠ WARNING

Never use a natural gas supply line, natural gas hose, or any other fuel item that appears to be damaged.

⚠ WARNING

- To reduce the risk of injury, perform a leak test any time the natural gas hose is disconnected and reconnected.
- Explosion hazard. If you smell methane, do not start the generator. Always completely close natural gas supply line valve and disconnect natural gas (NG) hose from generator when not in use.

1. Turn the generator off and allow the engine to cool for at least five minutes.
2. Verify that the gas is turned off at the natural gas supply line.

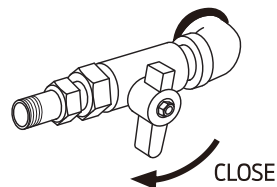

PREPARATIONS

3. Completely unwrap and straighten the natural gas hose to prevent kinks.
4. Contact your local gas company for guidance on accessory connection to a natural gas line. Your qualified contractor must minimally ensure the pipe supply line threads are clean and in good condition. Pipe connections must be made using a gas rated 'dope' or PTFE tape.

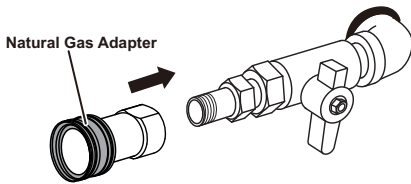

5. Pull the quick connect collet rearward, insert the natural gas hose nipple, then release the collet; ensure a solid connection is made.

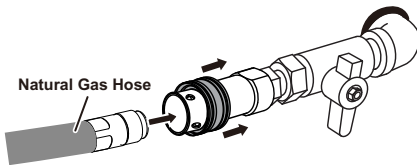

6. Push back the quick connector collet of the natural gas hose, insert it into the generator propane/methane inlet, loosen the quick connector sleeve, and make the sleeve clamp the propane/methane inlet.

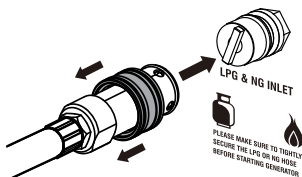

IMPORTANT: DO NOT use thread seal tape or any other type of sealant to seal the natural gas hose connection.

7. Turn the natural gas (NG) supply line valve to the fully open position. Check all connections for leaks by wetting the fittings with a solution of soap and water. Bubbles which appear or bubbles which grow indicate that a leak exists. If a leak exists at a fitting, turn the natural gas (NG) supply line valve to the fully closed position and tighten the fitting. Open the natural gas (NG) supply line valve and recheck the fitting with the soap and water solution.

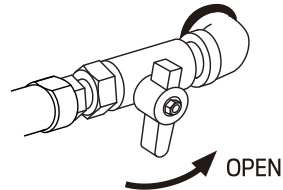

CONNECTING THE BATTERY

1. Open the access door.
2. A quick-connect battery plug is pre-installed on the battery. Remove the cable tie securing the plugs, align colors, then push firmly to connect them.

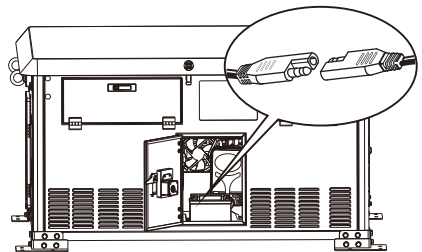

3. Reinstall the maintenance cover.

Note: The generator is equipped with a battery charging feature. Once the engine is running, a small current will slowly recharge the battery.

OPERATION

GENERATOR LOCATION

WARNING

NEVER operate the generator inside any building, garage, basement, crawlspace, shed, or enclosure, including the generator compartment of a recreational vehicle.

NEVER operate or start the generator in the back of an SUV, camper, trailer, truck bed (regular sides, flat or other configuration), under staircases, stairwells, next to walls or buildings, or any other location that could limit airflow or trap exhaust.

DO NOT operate or store the generator in wet weather conditions such as rain or snow. Using a generator in wet conditions could result in serious injury or death due to electrocution.

Generators must have a minimum of 5 feet (1.5 m) of clearance from all combustible material.

Generators must also have a minimum of 5 feet (1.5 m) of airflow clearance on all sides to allow for adequate cooling, maintenance, and service.

Always place the generator in a well-ventilated area. **NEVER** place the generator near air intake vents or where exhaust fumes could be drawn into occupied or confined spaces.

Always carefully consider wind and air currents when positioning the generator.

Always allow generators to properly cool before transport or for storage purposes.

Failure to follow proper safety precautions may result in personal injury, damage to the generator, and void your warranty.

WARNING

During operation, the muffler and exhaust fumes will become hot. If there is inadequate cooling space or if the generator is blocked or enclosed, temperatures can rise quickly and may lead to a fire.

STARTING THE GENERATOR

1. Place the generator in a safe, appropriate location.
2. Disconnect all electrical loads from the generator. Never start or stop the generator with electrical devices plugged in or turned on.
3. Check oil and fuel levels. If needed add oil, refill the LP gas cylinder, add gasoline, or contact your natural gas utility company.
4. Turn the Fuel Switch to desired fuel source.
 - When the Fuel Switch is in the Gasoline position, the generator is ready to start with Gasoline.
 - When the Fuel Switch is in the LPG position, the generator is ready to start with propane.
 - When the Fuel Switch is in the Natural Gas(NG) position, the generator is ready to start with methane.

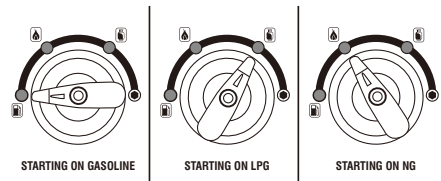

NOTE: Engine No. 1 and Engine No. 2 must use the same fuel. DO NOT use different fuels to start the generator.

5. Select Operating Mode: Choose to start Engine No. 1 (#1), Engine No. 2 (#2), or operate in parallel (#1+#2) based on your electricity needs.

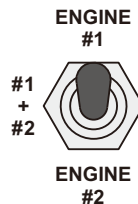

OPERATION

NOTE: If only one engine is started, the output power will only be half of the total rated power of the generator. If parallel operation is selected, the total rated power of the generator will be output.

⚠ WARNING

Before starting, Engine No. 1, Engine No. 2 or parallel operation must be selected. Do not switch modes when the generator is running, otherwise it may damage the generator.

6. Press LOW IDLE to "OFF".

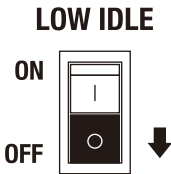

7. Press Main Switch to "ON".

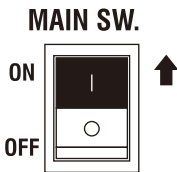

8. Choose the Starting Method

Recoil Start: Firmly grasp and pull the recoil handle slowly until you feel resistance, let it retract then pull swiftly.

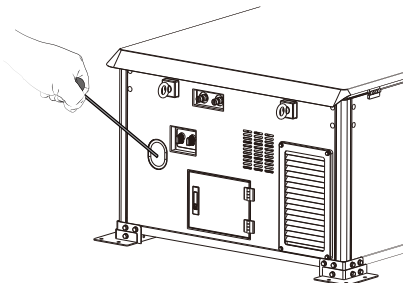

NOTE: Only Engine No. 2(#2) or parallel (#1+#2) can be selected for recoil start. Do not attempt to switch to Engine No. 1 after starting, nor switch the mode to Engine No. 1 to attempt recoil start of the generator.

NOTE: In the parallel operation mode, if you use the recoil start, the No. 2 engine will be started first. Approximately 5 minutes later, the No. 1 engine will automatically start. Do not insert any load during this period.

Push Button Start: Press the start button for 1-3 seconds, then release, to start the generator.

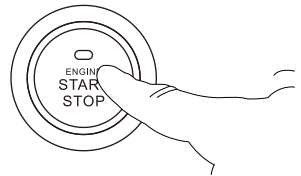

Remote Start: Push and hold the ON button on the remote start key fob for one second.

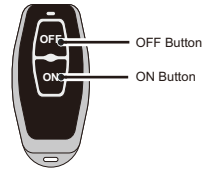

9. After about 3-5 seconds of startup, the running light will turn green and the circuit breaker will automatically close. At this time, the generator can output normally.

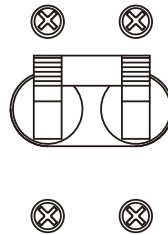

10. When the generator output stabilizes, you can safely connect loads to the control panel receptacles.

OPERATION

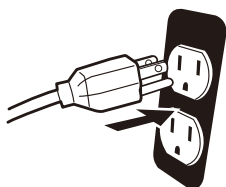

NOTE: Verify that all devices are turned off before connecting them to the generator.

NOTE: Make sure that the wattage requirements for all connected devices are in line with your generator's capabilities.

Fuel Switching

⚠ WARNING

Always perform fuel switching changeover with the generator completely shut down and cooled. Ensure fuel lines are properly purged and connections are leak-free before restarting to prevent fire or explosion hazards.

⚠ WARNING

When using the generator with propane(or methane), make sure there is no possible ignition source close to the generator.

⚠ DANGER

Fire and explosion hazard. Always turn the propane(or methane) tank valve to the fully closed position if not running the generator on propane(or methane).

Overload Indicator

Note: The OVERLOAD light may turn on for a few seconds as a large device starts. This is normal for loads approaching the capacity of this generator.

1. The total combined load through the outlets on the generator must not exceed the running power of the unit.
2. If the OVERLOAD light turns on and the generator stops producing power, it has been overloaded.

3. Turn off and disconnect all electrical devices and stop the engine. Compare device requirements to generator rating and reduce the total wattage of connected devices if necessary. Move anything that may be limiting generator ventilation away.
4. Check if any circuit breakers have tripped and make sure that ALL circuit breakers are reset before starting the generator again.
5. Restart the engine and reconnect devices while being careful to not overload the generator.

Low Oil Indicator

1. If the engine oil level is too low, the LOW OIL light turns on and the engine will automatically shut off.
2. The engine cannot be restarted until the proper amount of oil has been added. Add the appropriate type of oil until the oil level is at the proper level. SAE 10w-30 oil is recommended for general use.

ATTENTION

Do not run the engine with too little oil. Engine will shut off if engine oil level is too low.

Low Idle

1. Turn on a low idle mode to limit noise and fuel consumption with a light generator load.
2. Turn off the low idle mode to run the engine at full speed under the following conditions:
 - Starting the generator.
 - If the load exceeds 50%, it is recommended to turn off the low idle mode.

RECOIL START (The battery is dead)

When the generator battery is low on power, it is not possible to start the generator by pressing the button or using the remote key. In this case, the engine needs to be started using the recoil start method. Once the generator starts running, a small current will be generated to charge the battery.

OPERATION

- Place the generator in a safe, appropriate location.
- Disconnect all electrical loads from the generator. Never start or stop the generator with electrical devices plugged in or turned on.
- Check oil and fuel levels. If needed add oil, refill the LP gas cylinder, add gasoline, or contact your natural gas utility company.
- Turn the Fuel Switch to desired fuel source.
 - When the Fuel Switch is in the Gasoline position, the generator is ready to start with Gasoline.
 - When the Fuel Switch is in the LPG position, the generator is ready to start with propane.
 - When the Fuel Switch is in the Natural Gas(NG) position, the generator is ready to start with methane.

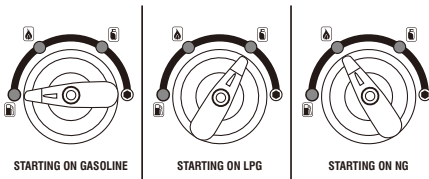

NOTE: Engine No. 1 and Engine No. 2 must use the same fuel. DO NOT use different fuels to start the generator.

- Select Engine No. 2 (#2) or the parallel (#1 + #2).

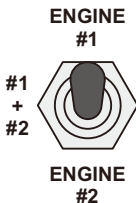

NOTE: Only Engine No. 2(#2) or parallel (#1+#2) can be selected for recoil start. Do not attempt to switch to Engine No. 1 after starting, nor switch the mode to Engine No. 1 to attempt recoil start of the generator.

- Press LOW IDLE to "OFF".

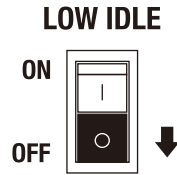

- Press Main Switch to "ON".

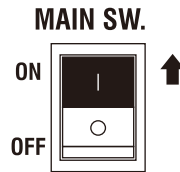

- Turn the choke valve of Engine No. 2 to "CLOSE".

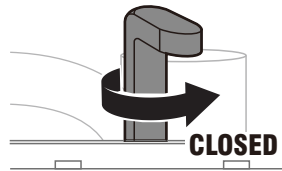

- Firmly grasp and pull the recoil handle slowly until you feel resistance, let it retract then pull swiftly.

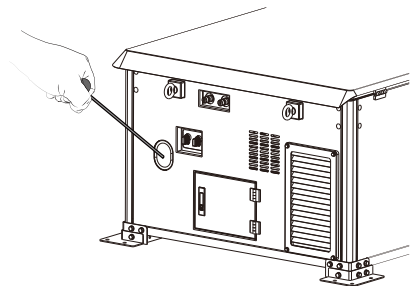

OPERATION

10. Turn the choke valve of Engine No. 2 to "OPEN".

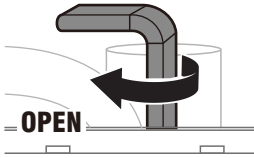

11. After about 3-5 seconds of startup, the running light will turn green and the circuit breaker will automatically close. At this time, the generator can output normally.

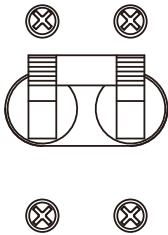

ATTENTION

Select Mode #2: After approximately 3 to 5 seconds of startup, the operation indicator light will turn green and the circuit breaker will automatically close. At this point, the generator can start to output electricity normally.

Select Mode #1 + #2: Engine No. 2 will start first. Approximately 5 minutes later, Engine No. 1 will automatically start. Once both engines are properly activated, the circuit breaker will automatically close.

12. When the generator output stabilizes, you can safely connect loads to the control panel receptacles.

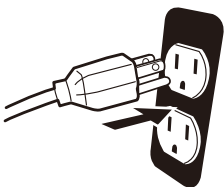

NOTE: Verify that all devices are turned off before connecting them to the generator.
NOTE: Make sure that the wattage requirements for all connected devices are in line with your generator's capabilities.

WARNING

To switch to # 1 mode, please turn off the generator before switching to the operating mode. Do not switch modes while the generator is running, as it may damage the generator.

ATTENTION

The No. 1 engine can only be started by using the button or the remote key. (Electric start)

STOPPING THE GENERATOR

1. Turn off and unplug all connected electrical loads. Never start or stop the generator with electrical devices plugged in or turned on.

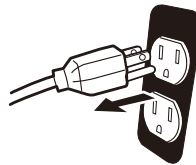

2. Select the Stopping Mode:

Button Stop: Press the button to turn off the generator.

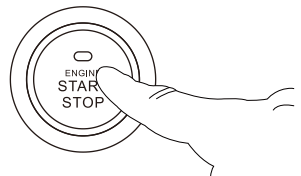

Remote Stop: Hold down the OFF button on the remote start key for one second.

OPERATION

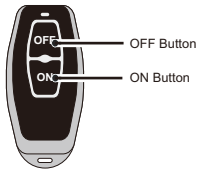

7. Remove or consume all untreated gasoline if you plan to store the generator longer than 3 months.
8. If the generator is not used for a long time, please disconnect the battery wiring.

3. Press the Main Switch to "OFF".
If not used for more than 48 hours, please turn off the Main Switch.

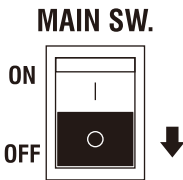

4. Turn the Fuel Selector knob to the OFF position.

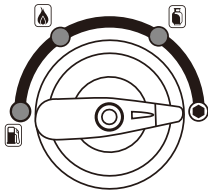

5. If using LPG or NG fuel, close the valve when not in use.

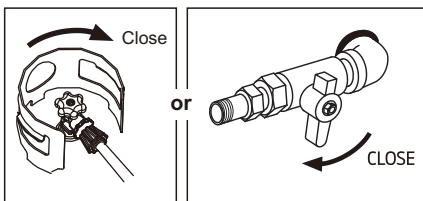

6. After the generator has completely cooled down, remove propane(or methane) hose if applicable and store the generator in a cool, dry, sheltered storage area.

USING THE GENERATOR

SERVICE ENVIRONMENT OF THE GENERATOR

- Applicable temperature: 23°F(-5°C)~104°F(40°C);
- Applicable humidity: below 95%;
- Applicable altitude: regions below 1,500 m (It shall be used by reducing power in regions above 1,000 m).

Standard atmospheric condition

- Ambient temperature Tr: 298k (77°F)(25°C)
- Relative air humidity Φr: 30%.
- Absolute atmospheric pressure Pr: 100kPa

When actual environmental condition is inconsistent with the condition of output power of the generator set:

- Every 41°F(5°C) of increase in ambient temperature will reduce the power of generator by about 2%
- Every 30% of increase in relative humidity of air will reduce the power of generator by about 1.5%
- Every 300 m rising of ASL will reduce the power the generator by about 4.5%

GENERATOR WIRING

- When the generator is connected to household power source as a backup power supply, the connection shall be carried out by a professional electrician or a person familiar with electricity.
- After connecting the load to the generator, check carefully whether electrical connection is safe and reliable. Improper electrical connection may cause generator damage, burning or fire.
- Avoid connecting this generator to commercial power outlet.
- When extending the cable, be sure not to exceed its length.

① 60m cross-section area is 1.5mm²

② 100m cross-section area is 2.5mm²

- The appearance of extension cable shall be protected by a layer of tough and elastic rubber cover (IEC25) or other substitutes.

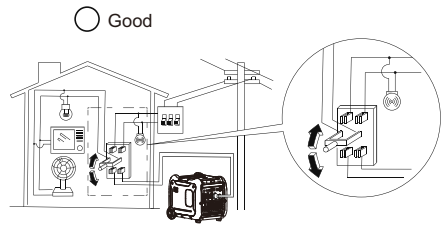
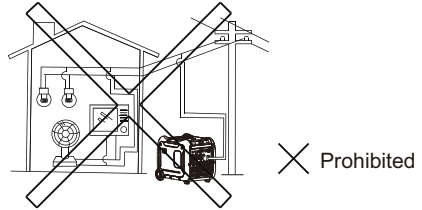
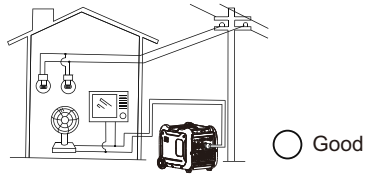

Connection of AC power

⚠ WARNING

All electrical equipment shall be disconnected before inserting the plug.

ATTENTION

- Make sure that all electrical equipment, including wires and plugs, are in good condition before connecting to the generator;
- Make sure that all loads driven by the generator are within rated load range;
- Make sure that load current is within rated current range of rated socket.

Tip: Make sure that the generator set is grounded, and if electrical equipment requires grounding, the generator set must be grounded.

USING THE GENERATOR

- ① Start up the engine;
- ② Turn energy-saving switch to "ON" ;
- ③ Insert the plug into AC outlet;
- ④ Make sure that AC indicator is lit up;
- ⑤ Switch on electrical equipment.

Tip: Before increasing engine speed, low idle switch must be switched to "OFF". If the generator set supplies power to multi loads or electrical equipment, start from large to small according to the size of each electrical equipment.

Generator Grounding

In order to prevent any damage to the generator caused by electric shock or improper electrical application, it is recommended that the generator is grounded with good conductor with insulating sheath.

- ① Please use grounding wire with sufficient electrical energy capacity;
- ② Connect one end of grounding wire reliable to grounding bolt on control panel of the generator set;
- ③ Insert grounding body (iron rod with a diameter of 5 ~ 10mm) 200mm below into the earth and lead it out with conductor;
- ④ Connect the other end of the grounding wire reliable to the led wire of grounding body.

RANGE OF APPLICATION

Before using the generator, please make sure that total load is within rated load range of the generator, otherwise the generator may be damaged.

Tip:

- AC and DC can be used at the same time, but total power amount shall not exceed rated output power.
- When total power exceeds rated power, overload indicator will light up.

SERVICE AND MAINTENANCE

Good maintenance and service is the best guarantee for safe, economical and reliable operation. It also contributes to environmental protection.

In order to keep the generator in good condition, you must inspect and maintain it regularly. The maintenance schedule is as follows:

Maintenance cycle		Each	First in 1 month or 20 hours	Then every three months or every 50 hours	100 hours per year or use
Engine oil	Check-fill	√			
	Replace		√	√	
Gearbox gear Oil (if any)	Check oil	√			
	Replace		√	√	
Air cleaner element	Inspection	√			
	Clean		√		
	Replace			√	
Settling cup (if any)	Clean				√
Spark plug	Clean-adjust				√*
Spark eliminator	Clean			√	
Idle speed (if any)**	Check-adjust				√
Valve clearance**	Check-adjust				√
Fuel tank and fuel filter***	Clean				√
Fuel line	Inspection	Every two years (Please replace if necessary)			
Cylinder head, piston	Remove carbon deposit**	Displacement < 225cc, every 125 hours; displacement capacity ≥ 225cc, every 250 hours.			
* These items shall be replaced if necessary;					
** These items shall be maintained by the dealer authorized by the Company, unless the user has proper tools and maintenance ability.					

ATTENTION

- If it often works under high temperature or high load, oil shall be changed every 25 hours;
- If it often works in dusty or harsh environment, air cleaner element shall be cleaned every 10 hours. If necessary, the air cleaner element shall be replaced every 25 hours;
- It shall be maintained on spot-inspection or on regularly scheduled inspections;
- If maintenance cycle time has elapsed, perform the maintenance as soon as possible as per the table above.

SERVICE AND MAINTENANCE

⚠ WARNING

Please shut down the engine first before performing any maintenance. The engine shall be placed in a horizontal position. In order to prevent the engine from starting up, separate spark plug cap shall be separated from spark plug.

⚠ WARNING

Do not use it indoors or use it in a tunnel, cave or other places ventilated poorly. Make sure that work area is well ventilated. Exhaust gas from the engine contains toxic gases, carbon oxides, and the inhalation can cause shock, loss of consciousness, and even death.

ENGINE OIL CHANGE

⚠ WARNING

Do not drain the oil immediately after turning off the generator. During operation, the oil is very hot and can cause serious burns.

1. Confirm that the generator is stopped and powered off.
2. Open the oil access door.
3. Find the oil drain hose (to the left of the dipstick), place an oil basin (or suitable container), unscrew the cap of the oil hose, tilt, wait for the oil to drain completely. Recycle used oil.

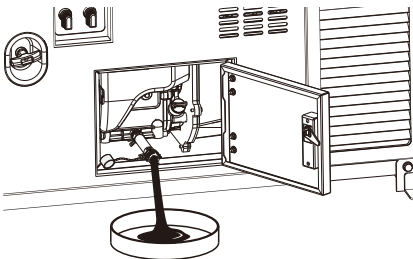

4. Replace the oil drain hose cap. Put the oil drain hose back into the generator.
5. Add the appropriate type of oil until the oil level is at the proper level. SAE 10w-30 oil is recommended for general use.

Note: Make sure the generator is level when adding oil to prevent overfilling which could cause engine damage.

6. Check the oil level. The oil level should be just below the edge of the hole as shown.

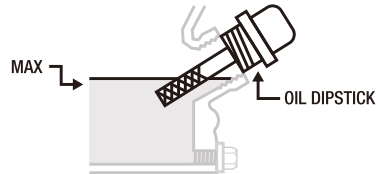

7. Thread the oil dipstick back in clockwise.

ATTENTION

Do not attempt to run the engine with too little oil. The engine will not start with low or no engine oil.

NOTE: Engine No. 1 and Engine No. 2 need to undergo the above maintenance simultaneously.

SPARK PLUG MAINTENANCE

1. Confirm that the generator is stopped and powered off.
2. Open the access door.

#1 ENGINE

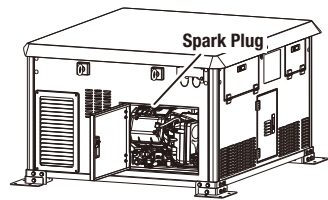

#2 ENGINE

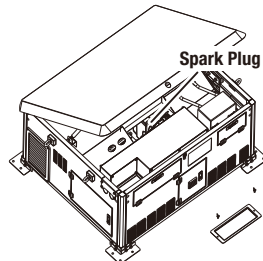

SERVICE AND MAINTENANCE

3. Disconnect Spark Plug Cap from the end of plug. Clean out debris from around Spark Plug.

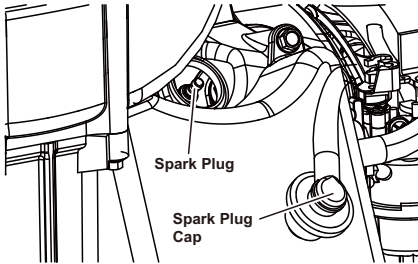

4. Using the Spark Plug Wrench, remove the Spark Plug.
5. Inspect the Spark Plug: If the electrode is oily, clean it using a clean, dry rag. If the electrode has deposits on it, clean it with a brass wire brush. If the white insulator is cracked or chipped, replace the spark plug.

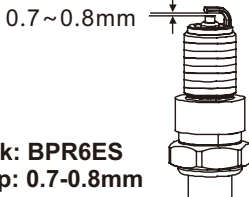

Standard spark: BPR6ES
Spark plug gap: 0.7-0.8mm

Tip: The spark plug clearance is required to be measured by line thickness gauge, which shall be adjusted if necessary.

6. When installing a new spark plug, adjust the plug's gap to the specification on the Specifications Chart. Do not pry against the center electrode, the spark plug can be damaged.
7. Apply anti-seize material to Spark Plug threads. Install the new spark plug or the cleaned spark plug into the engine.

Spark cold torque: 22 N.m

Tip: If there is no torque wrench when installing the spark plug, a better estimation method is to screw it 1/4-1/2 turns by force after screwing it in place, but the spark plug shall be screwed to specified torque as soon as possible.

ATTENTION

Tighten the Spark Plug properly. If loose, the Spark Plug will cause the engine to overheat. If over tightened, the threads in the engine block will get damaged.

8. Replace Spark Plug Cap and access door.

NOTE: Engine No. 1 and Engine No. 2 need to undergo the above maintenance simultaneously.

AIR FILTER

Dirty air cleaner may prevent air from flowing into the carburetor. In order to prevent failure of the carburetor, please maintain air cleaner regularly. If being used in a dusty environment, it shall be maintained frequently.

1. Confirm that the generator is stopped and powered off.
2. Open the access door.
3. Unsnap the Air Filter Cover Clip and remove Air Filter Cover. See the figure below.
4. Remove Air Filter.

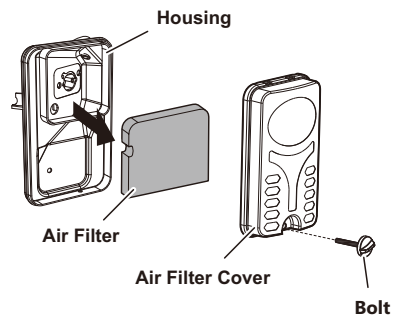

SERVICE AND MAINTENANCE

4. Clean the components with cleaning agent. After cleaning, wrap the components in a cloth and screw them dry.

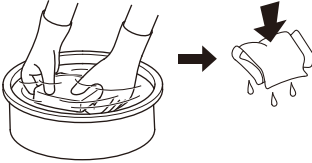

5. Drip a few drops of oil to foam filter element and squeeze off excess oil. The foam cleaner element shall be wet, but there shall not be oil dripping.

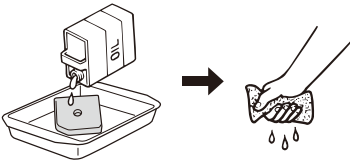

ATTENTION

Be sure not to twist the foam cleaner element forcibly to avoid damage.

6. Put foam cleaner element into air cleaner.

Tip: Make sure that the surface of foam cleaner element is in close contact with air cleaner, and there shall be no gap leaking air.

7. Reassemble empty air cleaner cap back to original position, and tighten screws.

ATTENTION

Be sure not to start the engine before air cleaner is assembled, because it will generate excessive toxic gas and wear the cylinder.

NOTE: Engine No. 1 and Engine No. 2 need to undergo the above maintenance simultaneously.

STORAGE AND TRANSPORT

GENERATOR STORAGE

If it is stored long-term, in order to prevent aging, you shall take some storage measures.

1. Turn off the generator.
2. Open fuel tank cap, to take out fuel filter screen. Pump all fuel in fuel tank into special fuel tank, and then reassemble fuel tank cap back.

Tip: Do not connect any electrical equipment. Running time of the engine depends on remaining fuel in the fuel tank.

3. Unscrew fuel drain bolt on the carburetor, and drain fuel in the carburetor into special fuel tank. Tighten fuel drain bolt.

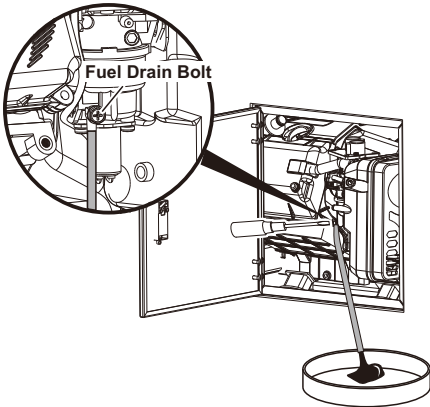

4. Unscrew oil dipstick, and drain oil in the crankcase off. Fill new oil to upper oil limit, and then assemble oil dipstick.
5. Remove the spark plug and pour 5-10ml of clean oil into the combustion chamber. Turn the crankshaft a few times to distribute the oil, then reassemble the spark plug.

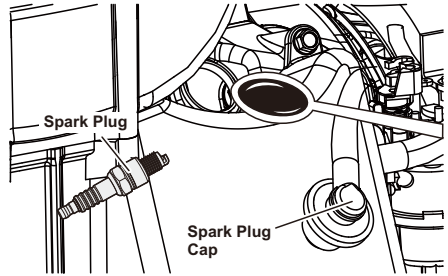

6. Gently pull startup handle until you feel resistance, allowing both inlet valve and exhaust valve to be closed.
7. Disconnect the battery.
8. Place the generator set in a clean and dry area.

GENERATOR TRANSPORT

- When transporting the generator set, it should be stored separately from the fuel tank.
- Do not run the generator, and avoid direct sunlight.
- Do not transport the generator set on rough road for long time.

PREPARATION FOR USE AFTER STORAGE

1. Slowly pull the starter cord a few times to clean oil from the cylinder or to eject any pump protector from the pump which may have been added prior to storage.
2. Remove the spark plug from the cylinder. Wipe oil from the spark plug and return it to the cylinder and re-tighten.
3. Reconnect the spark plug wire.
4. Refuel engine per earlier instructions in this manual.

TROUBLESHOOTING

Problem	Possible Causes	Probable Solutions
Engine will not start	FUEL RELATED: <ol style="list-style-type: none"> No fuel in tank or fuel valve closed. Choke not in START position, cold engine. Gasoline with more than 10% ethanol used. (E15, E20, E85, etc.) Low quality or deteriorated, old gasoline. Carburetor not primed. Dirty fuel passageways. Carburetor needle stuck. Fuel can be smelled in the air. Too much fuel in chamber. This can be caused by the carburetor needle sticking. Clogged Fuel Filter. 	FUEL RELATED: <ol style="list-style-type: none"> Fill fuel tank with fresh 87+ octane stabilizer-treated unleaded gasoline and open fuel valve. Do not use gasoline with more than 10% ethanol (E15, E20, E85, etc.). Move Choke to START position. Clean out ethanol rich gasoline from fuel system. Replace components damaged by ethanol. Use fresh 87+ octane stabilizer-treated unleaded gasoline only. Do not use gasoline with more than 10% ethanol (E15, E20, E85, etc.). Use fresh 87+ octane stabilizer-treated unleaded gasoline. Do not use gasoline with more than 10% ethanol (E15, E20, E85, etc.). Pull on Starter Handle to prime. Clean out passageways using fuel additive. Heavy deposits may require further cleaning. Gently tap side of carburetor float chamber with screwdriver handle. Turn Choke to RUN position. Remove spark plug and pull the start handle several times to air out the chamber. Reinstall spark plug and set Choke to START position. Replace Fuel Filter.
	IGNITION (SPARK) RELATED: <ol style="list-style-type: none"> Power Switch at OFF position. Spark plug cap not connected securely. Spark plug electrode wet or dirty. Incorrect spark plug gap. Spark plug cap broken. Circuit breaker tripped (electric start models only). Incorrect spark timing or faulty ignition system. 	IGNITION (SPARK) RELATED: <ol style="list-style-type: none"> Turn Power Switch to ON. Connect spark plug cap properly. Clean spark plug. Correct spark plug gap. Replace spark plug cap. Reset circuit breaker. Check wiring and starter motor if breaker continues to trip. Have qualified technician diagnose/ repair ignition system.
	COMPRESSION RELATED: <ol style="list-style-type: none"> Cylinder not lubricated. Problem after long storage periods. Loose or broken spark plug. (Hissing noise will occur when trying to start.) Loose cylinder head or damaged head gasket. (Hissing noise will occur when trying to start.) Engine valves or tappets mis-adjusted or stuck. 	COMPRESSION RELATED: <ol style="list-style-type: none"> Pour tablespoon of oil into spark plug hole. Crank engine a few times and try to start again. Tighten spark plug. If that does not work, replace spark plug. If problem persists, may have head gasket problem, see #3. Tighten head. If that does not remedy problem, replace head gasket. Have qualified technician adjust/ repair valves and tappets.
	ENGINE OIL RELATED: <ol style="list-style-type: none"> Low engine oil. Engine mounted on slope, triggering low oil shutdown. 	ENGINE OIL RELATED: <ol style="list-style-type: none"> Fill engine oil to proper level. Check engine oil before EVERY use. Operate engine on level surface. Check engine oil level.
	SPARK ARRESTOR RELATED: <ol style="list-style-type: none"> Spark Arrestor clogged with soot. 	SPARK ARRESTOR RELATED: <ol style="list-style-type: none"> Clean and replace Spark Arrestor.



Follow all safety precautions whenever diagnosing or servicing the generator or engine.

The table is a general troubleshooting method. If the fault is inconsistent with the table or the fault cannot be resolved, contact the distributor.

TROUBLESHOOTING

Problem	Possible Causes	Probable Solutions
Engine misfires	<ol style="list-style-type: none"> 1. Spark plug cap loose. 2. Incorrect spark plug gap or damaged spark plug. 3. Defective spark plug cap. 4. Old or low quality gasoline. 5. Incorrect compression. 	<ol style="list-style-type: none"> 1. Check cap and wire connections. 2. Re-gap or replace spark plug. 3. Replace spark plug cap. 4. Use only fresh 87+ octane stabilizer-treated unleaded gasoline. Do not use gasoline with more than 10% ethanol (E15, E20, E85, etc.). 5. Diagnose and repair compression. (Use Engine will not start: COMPRESSION RELATED section.)
Engine stops suddenly	<ol style="list-style-type: none"> 1. Carbon Monoxide level high. Red light on Carbon Monoxide Sensor illuminates. 2. CO Sensor Alarm flashes yellow continually shortly after starting. 3. CO Sensor Alarm flashes yellow continually after longer period of operation. 4. Low oil shutdown. 5. Fuel tank empty or full of impure or low quality gasoline. 6. Defective fuel tank cap creating vacuum, preventing proper fuel flow. 7. Faulty magneto. 8. Disconnected or improperly connected spark plug cap. 	<ol style="list-style-type: none"> 1. Leave area immediately and allow area to ventilate thoroughly. Only operate generator outside. 2. Carbon monoxide sensor malfunction. Sensor needs service. Do not use the Generator until the sensor is working properly. 3. Make sure to operate generator within rated ambient temperature; maintain minimum 5 ft. clearance from all sides. 4. Fill engine oil to proper level. Check engine oil before EVERY use. 5. Fill fuel tank with fresh 87+ octane stabilizer treated unleaded gasoline. Do not use gasoline with more than 10% ethanol (E15, E20, E85, etc.). 6. Test/replace fuel tank cap. 7. Have qualified technician service magneto. 8. Secure spark plug cap.
Engine stops when under heavy load	<ol style="list-style-type: none"> 1. Dirty air filter 2. Engine running cold. 	<ol style="list-style-type: none"> 1. Clean element. 2. Allow engine to warm up prior to operating equipment.
Engine knocks	<ol style="list-style-type: none"> 1. Old or low quality gasoline. 2. Engine overloaded. 3. Incorrect spark timing, deposit buildup, worn engine, or other mechanical problems. 	<ol style="list-style-type: none"> 1. Fill fuel tank with fresh 87+ octane stabilizer-treated unleaded gasoline. Do not use gasoline with more than 10% ethanol (E15, E20, E85, etc.). 2. Do not exceed equipment's load rating. 3. Have qualified technician diagnose and service engine.
Engine backfires	<ol style="list-style-type: none"> 1. Impure or low quality gasoline. 2. Engine too cold. 3. Intake valve stuck or overheated engine. 4. Incorrect timing. 	<ol style="list-style-type: none"> 1. Fill fuel tank with fresh 87+ octane stabilizer-treated unleaded gasoline. Do not use gasoline with more than 10% ethanol (E15, E20, E85, etc.). 2. Use cold weather fuel and oil additives to prevent backfiring. 3. Have qualified technician diagnose and service engine. 4. Check engine timing.
Attached device doesn't have power	<ol style="list-style-type: none"> 1. Device not plugged in properly. 2. Circuit Breaker tripped. 3. Product needs service. 	<ol style="list-style-type: none"> 1. Turn off and unplug the device, then plug it back in again and turn on. 2. Turn off and unplug device, reset Circuit Breaker, plug in device and turn on. 3. Have product repaired.
Attached device begins to operate abnormally	<ol style="list-style-type: none"> 1. Problem with device. 2. Rated load capacity exceeded. 	<ol style="list-style-type: none"> 1. Immediately unplug device. Have device repaired by a qualified technician, or replace device. 2. Lower the number of items plugged into the generator to stay within the rated capacity, or use a more powerful generator.



Follow all safety precautions whenever diagnosing or servicing the generator or engine.

The table is a general troubleshooting method. If the fault is inconsistent with the table or the fault cannot be resolved, contact the distributor.

TECHNICAL PARAMETERS

Item	GM14000i-HSB
Rated Power (kW)	13(GAS.)/11.5(LPG)/10(NG)
Max. Power (kW)	14(GAS.)/12.5(LPG)/11(NG)
Engine Model	180F/P-GS
Valve Clearance	Input valve: 0.10~0.15 mm, Output valve: 0.15~0.20 mm
Stroke × Bore (mm)	80×62
Engine Type	4-stroke
Displacement (cc)	312
Gas Distribution Mode	OHV
Cooling Mode	Forced Cooling Wind
Rated Speed (RPM)	3800
Starting Method	Recoil Start / Electrical Start / Remote Start
Fuel Type	Gasoline / Propane(LPG) / Natural Gas(NG)
Lubricating Oil Capacity (gal)	0.2(0.8L)
Lubricating Oil Model	SAE 10W/30
Noise dB (at 7m)(25% load)	63
Rated Voltage (V)	120/240
Rated Frequency (Hz)	60
Rated Power Factor	1
Phase Number	Single Phase
Overall Dimension (in.)	47.8×40.7×25(1214×1034×633mm)
Net Weight (lb.)	518 (235kg)



In production management, based on orderly, efficient, scientific principles. trying to do as better as possible in product design, development, production, inspection, etc. to make our production can keep orderly. And will continue to make improvement to make sure that keep the competitiveness.

Welcome friends at home and abroad to visit and guide, work together to create brilliant.

GENMAX[®]

ADD: 301 Doubleday Ave Ontario CA 91761

Phone [866-960-2920](tel:866-960-2920)...

E-mail service@genmaxpower.com...

Http://www.genmaxpower.com



Facebook



LinkedIn



YouTube

