

# INVERTER GENERATOR USER'S MANUAL



**GM4000XiD-NFT**  
Portable Dual Fuel Generator

 **4000/3200**  
STARTING WATTS    RUNNING WATTS

 **3800/3000**  
STARTING WATTS    RUNNING WATTS



**WARNING:** SAVE THIS MANUAL FOR FUTURE REFERENCE



This manual contains important information regarding safety. Operation, maintenance and storage of this product. Before use, read carefully and understand all cautions, warnings, instructions and product labels. Failure to do so could result in serious personal injury and/or property damage.

**California  
Proposition 65 Warning**

The engine exhaust from this product contains chemicals known to the state of California to cause cancer, birth defects or other reproductive harm.

**California  
Proposition 65 Warning**

Certain components in this product and its related accessories contain chemicals known to the state of California to cause cancer, birth defects or other reproductive harm. Wash hands after handling.

**DISCLAIMERS:**

All information, illustrations and specifications in this manual are based on the latest information available at the time of publishing. The illustrations used in this manual are intended as representative reference views only. Moreover, because of our continuous product improvement policy, we may modify information, illustrations and/or specifications to explain and/or exemplify a product, service or maintenance improvement. We reserve the right to make any change at any time without notice. Some images may vary depending upon which model is shown.

**ALL RIGHTS RESERVED:**

No part of this publication may be reproduced or used in any form by any means - graphic, electronic or mechanical, including photocopying, recording, taping or information storage and retrieval systems - without the written permission of CHONGQING DINKING POWER MACHINERY CO., LTD

**⚠ DANGER**



This manual contains important instructions for operating this inverter generator. For your safety and the safety of others, be sure to read this manual thoroughly before operating the generator. Failure to properly follow all instructions and precautions can cause you and others to be seriously hurt or killed.

**UNPACKING**

**⚠ CAUTION**



Always have assistance when lifting the generator. The generator is heavy; lifting it could cause bodily harm.



Avoid cutting on or near staples to prevent personal injury.

**WHAT COMES IN THE BOX**

- Spark Plug Socket Wrench (1)
- Dual-Purpose Screwdriver (1)
- Hexagonal Wrench (1)
- User Manual (1)
- Warranty Information (1)
- Funnel (1)
- Fuel Tank Connection Hose (1)
- LPG Hose (1)
- Exhaust Plug (1)

**Tools required** - box cutter or similar device.

- Carefully cut the packing tape on top of the carton.
- Remove socket wrench, and oil funnel and save for later.
- Carefully cut two sides of the carton to remove the generator.

# DESCRIPTION OF FITTINGS

**Spark Plug Socket Wrench**



Used in spark plug maintenance, inspection, and installation.

**Dual-Purpose Screwdriver**



Phillips and slot blade screwdriver used for generator maintenance.

**Funnel**



It's used to oil the generator.

**Hexagonal Wrench**



Used to remove and install generator accessories.

**Fuel Tank Connection Hose**



It is used to connect the fuel tank to the generator and transmit gasoline to the generator.

**Exhaust Plug**



Used to drain air inside the tank connection hose.

**LPG Hose**

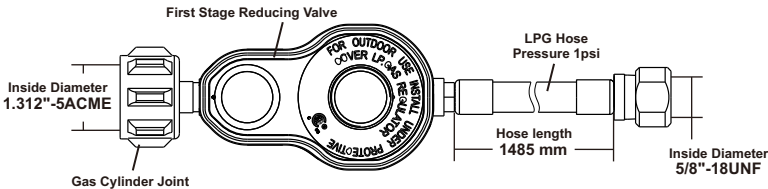
Connect the LPG tank to transmit LPG fuel to the generator.

The diagram labels the following components and specifications:

- Gas Cylinder Joint
- Inside Diameter 1.312"-5ACME
- First Stage Reducing Valve
- FOR OUTDOOR USE COVER UP TO 50°F PROTECTIVE INSULATION REQUIRED
- LPG Hose Pressure 1psi
- Hose length 1485 mm
- Inside Diameter 5/8"-18UNF

**Note:** Actual tools may differ in appearance or design from image shown.

# LIMITED WARRANTY

1. DURATION : One (1) year from the date of purchase by the original purchaser ( retail customer ) on products used solely for consumer applications; if a product is used for business, commercial, or industrial applications, the warranty period will be limited to ninety (90) days from the date of purchase.
2. WHO GIVES THIS WARRANTY (WARRANTOR):  
CHONGQING DINKING POWER MACHINERY CO., LTD
3. WHO RECEIVES THIS WARRANTY(PURCHASER):The original purchaser (other than for purposes of resale) of the Genmax's inverter.
4. WHAT PRODUCTS ARE COVERED BY THIS WARRANTY: Any portable generator supplied or manufactured by Warrantor.
5. WHAT IS COVERED UNDER THIS WARRANTY: Substantial defects on material and workmanship which occur within the duration of the warranty period.
6. WHAT IS NOT COVERED UNDER THIS WARRANTY:
  - A. Transportation charges for sending the product to Warrantor or its authorized service representative for warranty service, or for shipping repaired or replacement products back to the customer; these charges must be borne by the customer.
  - B. Damages caused by abuse, accident, shipping, misuse, overloading, modification, and the effects of corrosion, erosion and normal wear and tear.
  - C. Warranty is voided if the customer fails to install, maintain and operate the product in accordance with the instructions and recommendations set forth in the owner's manual(s), or if the product is used as rental equipment.
  - D. Pre-delivery service, i.e. assembly, oil or lubricants, and adjustment.
  - E. Items or service that are normally required to maintain the product, i.e. lubricants and filters.
  - F. Warrantor will not pay for repairs or adjustments to the product, or for any costs or labour, performed without Warrantor's prior authorization.

EXCLUSIONS AND LIMITATIONS : Warrantor makes no other warranty of any kind, express or implied. Implied warranties, including warranties of merchantability and of fitness for a particular purpose, are hereby disclaimed. This warranty service described above is the exclusive remedy under this warranty; liability for incidental and consequential damages is excluded to the extent permitted by law.

7. RESPONSIBILITIES OF PURCHASER UNDER THIS WARRANTY:
  - A. The purchaser must provide dated proof of purchase and must notify Warrantor within the warranty period.
  - B. Deliver or ship the serviced generator or component to the nearest Warrantor's authorized service representative. Freight costs, if any, must be borne by the purchaser.
8. HAVE QUESTIONS?

Email: [service@genmaxpower.com](mailto:service@genmaxpower.com) Phone: 866-960-2920

---

## WARRANTY CARD

### PERSONAL INFORMATION

Name: \_\_\_\_\_  
Street Address: \_\_\_\_\_  
City, State, ZIP: \_\_\_\_\_  
Country: \_\_\_\_\_  
Phone Number: \_\_\_\_\_  
E-Mail: \_\_\_\_\_

### INVERTER INFORMATION

Model Number: \_\_\_\_\_  
Serial Number: \_\_\_\_\_  
Date Purchased: \_\_\_\_\_  
Purchased From: \_\_\_\_\_



# TABLE OF CONTENTS

<b>LIMITED WARRANTY</b>	<b>3</b>
<b>SAFETY WARNING</b>	<b>5</b>
<b>SAFETY INSTRUCTIONS</b>	<b>6</b>
<b>NAMES OF COMPONENTS</b>	<b>8</b>
<b>CONTROL FUNCTIONS</b>	<b>10</b>
<b>PREPARATIONS</b>	<b>11</b>
1.Fuel.....	11
2.LPG.....	12
2.Oil.....	13
3.Pre-Operation Inspection.....	13
<b>STARTING UP THE GENERATOR</b>	<b>14</b>
<b>SHUTTING DOWN THE GENERATOR</b>	<b>16</b>
<b>USING THE GENERATOR</b>	<b>17</b>
1.Service Environment of the Generator.....	17
2.Generator Wiring.....	17
3.Generator Grounding.....	18
4.Parallel and Series Operation.....	19
<b>SERVICE AND MAINTENANCE</b>	<b>20</b>
1.Spark Plug Inspection.....	21
2.Adjustment of the Carburetor.....	22
3.Replacement of Oil.....	22
4.Air Filter.....	23
<b>STORAGE AND TRANSPORT</b>	<b>24</b>
1.Generator Storage.....	24
2.Generator Transport.....	25
<b>TROUBLESHOOTING</b>	<b>25</b>
<b>TECHNICAL PARAMETERS</b>	<b>26</b>
<b>CIRCUIT DIAGRAM</b>	<b>27</b>
<b>CHOOSING A GENERATOR</b>	<b>29</b>
<b>OPTIONAL</b>	<b>30</b>

# SAFETY WARNING



Personal and property safeties of you and others are very vital. Please read the Safety Warning in the User's Manual and the decals of the generator set carefully. The Safety Warning can alert you to those potential hazards that could harm you and others. In front of each Safety Warning, there is one of four words "**DANGER**", "**WARNING**", "**ATTENTION**", and "**CAREFUL**". Details are as follows:

## DANGER

Failure to follow the instruction will result in being in peril of your life or extremely serious injury.

## WARNING

Failure to follow the instruction will result in being in peril of your life or very serious injury.

## CAREFUL

Failure to follow the instruction will result in minor injury.

## ATTENTION

Failure to follow the instruction will result in the damage to your generator set and other properties.

## CO TECHNICAL WARNING

For portable generators where the neutral is floating, the operator's manual shall include the following wording CO DETECT technology monitors the accumulation of carbon monoxide (CO), a poisonous gas produced by engine exhaust when the generator is running. If CO Sensor detects unsafe elevated levels of CO gas, it automatically shuts off the engine. CO Sensor is not a substitute for an indoor carbon monoxide alarm or for safe operation. DO NOT allow engine exhaust fumes to enter a confined area through windows, doors, vents or other openings. Generators must ALWAYS be used outdoors, far away from occupied buildings with engine exhaust pointed away from people and buildings. Meets the requirements of ANSI/PGMA G300-2018.

## NEUTRAL FLOATING

For portable generators where the neutral is floating, the operator's manual shall include the following wording or equivalent:

The portable generator stator winding is isolated from the frame and from the AC receptacle ground pin; and Electrical devices that require a connection between one conductor pin and the grounded receptacle pin may not function properly.

# SAFETY INSTRUCTIONS

Before operating the generator, it will help you avoid accidents to read and understand the Manual and familiarize yourself with the safe operation procedures of the generator.

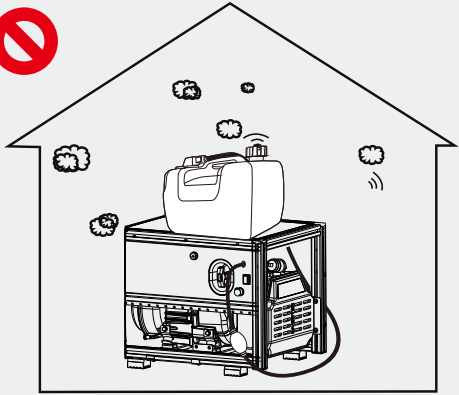

Please do not use indoors

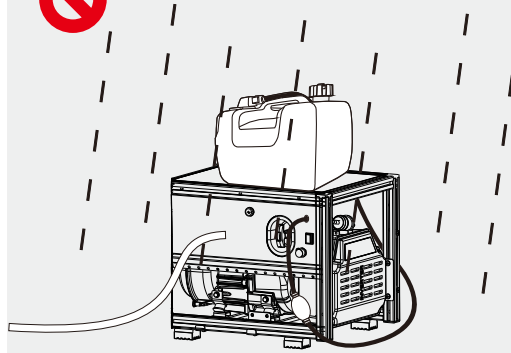

Please do not use in humid environment

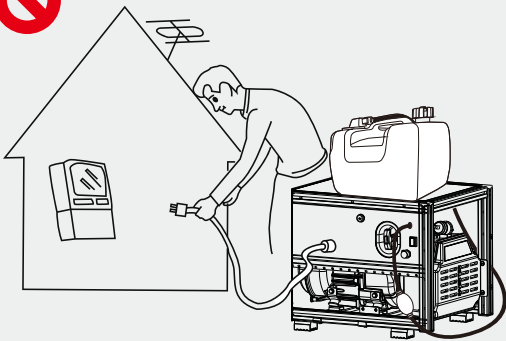

Please do not connect it to household appliances directly

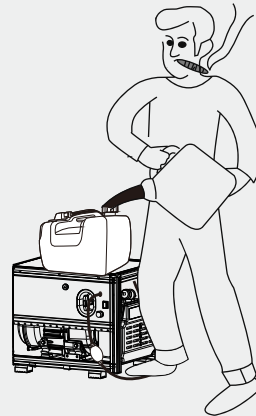

Please do not smoke when refueling

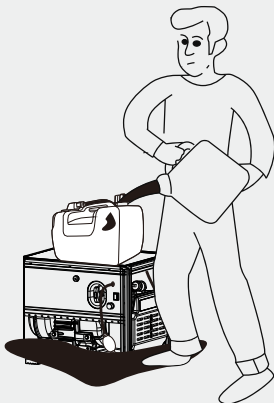

Please do not spill when refueling



Please shut down the generator before refueling

# SAFETY INSTRUCTIONS

## SAFETY LABELS AND DECALS

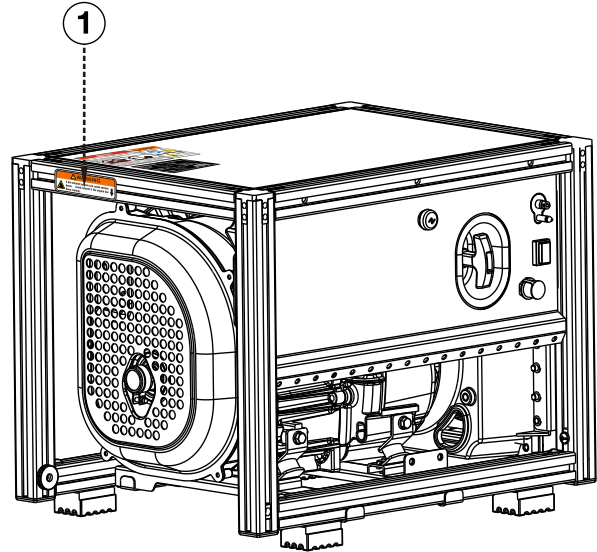
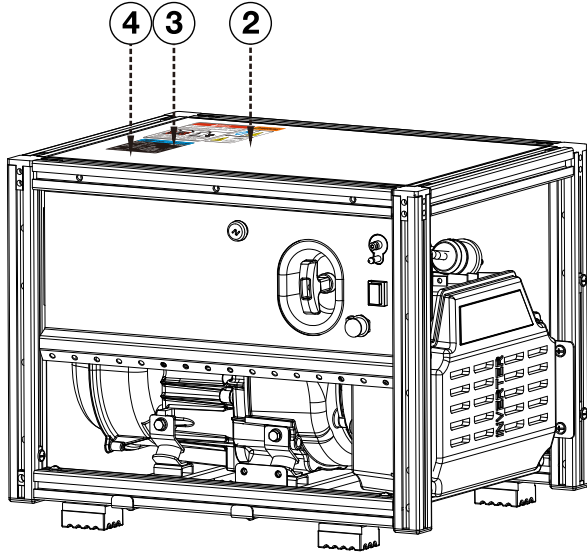

1



2

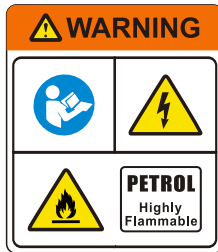

3

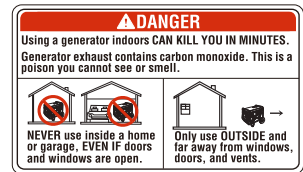

4

**GM4000XiD-NFT DUAL-FUEL Inverter Generator**

AC Voltage:	120V	Phase:	Single
Current:	26.7A - GAS	RPM:	4850
	25.0A - LPG	Power Factor:	1.0
Frequency:	60Hz	Insulation Class:	F
Rated Power:	3.2kW - GAS	Rated Amb. Temp.:	25°C
	3.0kW - LPG		
DC Output	12V 8.3A		

**GENMAX**  
CHONGQING DINKING POWER MACHINERY CO.,LTD. MADE IN CHINA



# NAMES OF COMPONENTS

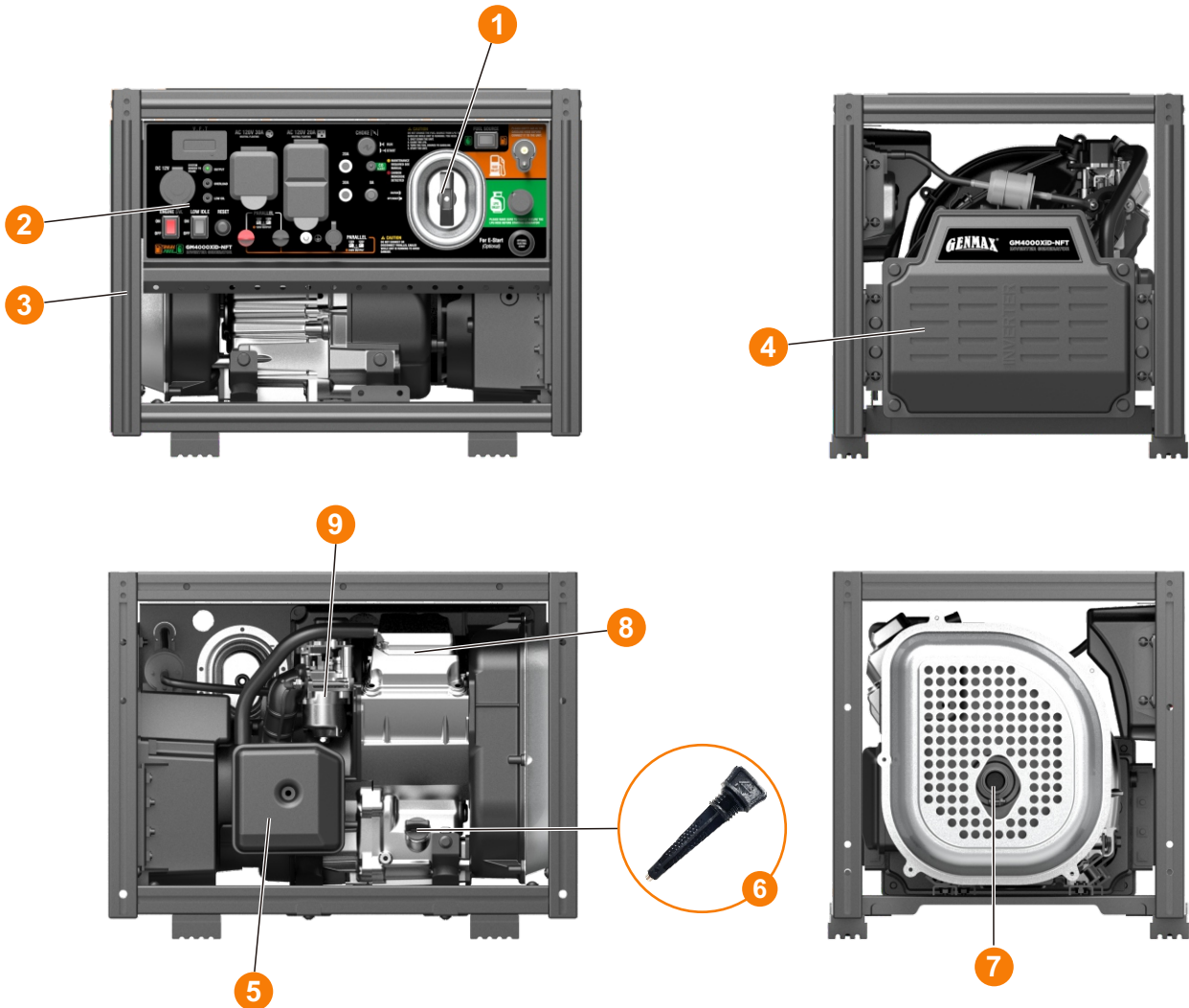

- ① **Recoil Handle:** Pull to start the engine.
- ② **Control Panel:** Contains the reset breaker, outlets and warning lights.
- ③ **Generator Frame:** Protects the generator for easy movement.
- ④ **Inverter:** A device that converts the power supply generated by a permanent magnet motor into a DC power supply, and converts the DC power supply after rectification into an AC power supply whose frequency and voltage can be adjusted, and at the same time controls the ability of the engine to adjust the speed according to the load.

- ⑤ **Air Cleaner:** Purify the air.
- ⑥ **Magnetic Oil Dipstick:** absorb iron filings in the oil, it is recommended to screw down the magnetic oil dipstick and clean it every 50 hours.
- ⑦ **Muffler:** Avoid contact until the engine is cooled down. The spark arrestor prevents sparks from exiting the muffler. It must be removed for servicing.
- ⑧ **Cylinder Head**
- ⑨ **Carburetor**

# NAMES OF COMPONENTS

## INSTALL RUBBER FEET AND RACK PLUG COVER

### List of Parts

<p>QTY: 4</p>  <p><b>Bolt M6×25</b></p>	<p>QTY: 4</p>  <p><b>Elastic Nut</b></p>	<p>QTY: 4</p>  <p><b>Plug Cover</b></p>
<p>QTY: 4</p>  <p><b>Rubber Foot</b></p>	<p>QTY: 4</p>  <p><b>Socket Wrench</b></p>	

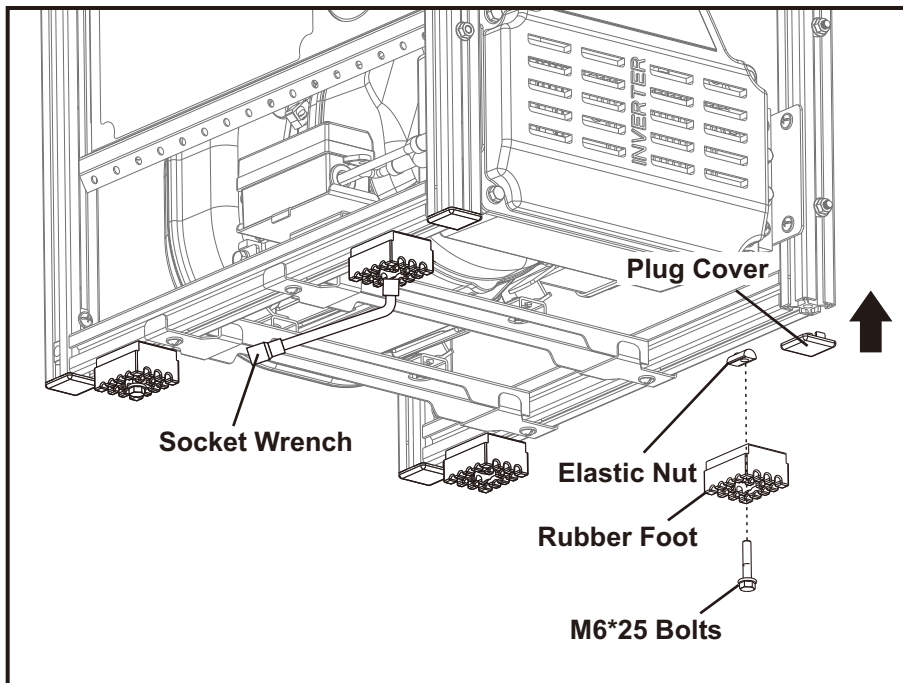

1. Install the plug cover at the bottom of the rack column.
2. Place the elastic nut into the groove at the lower side of the rack, and align the nut hole with the rubber foot mounting hole. *(Note: the side with the ball goes into the groove)*
3. Thread the bolts through the rubber feet and elastic nuts, and secure the rubber feet to the rack using a socket wrench.

# CONTROL FUNCTIONS

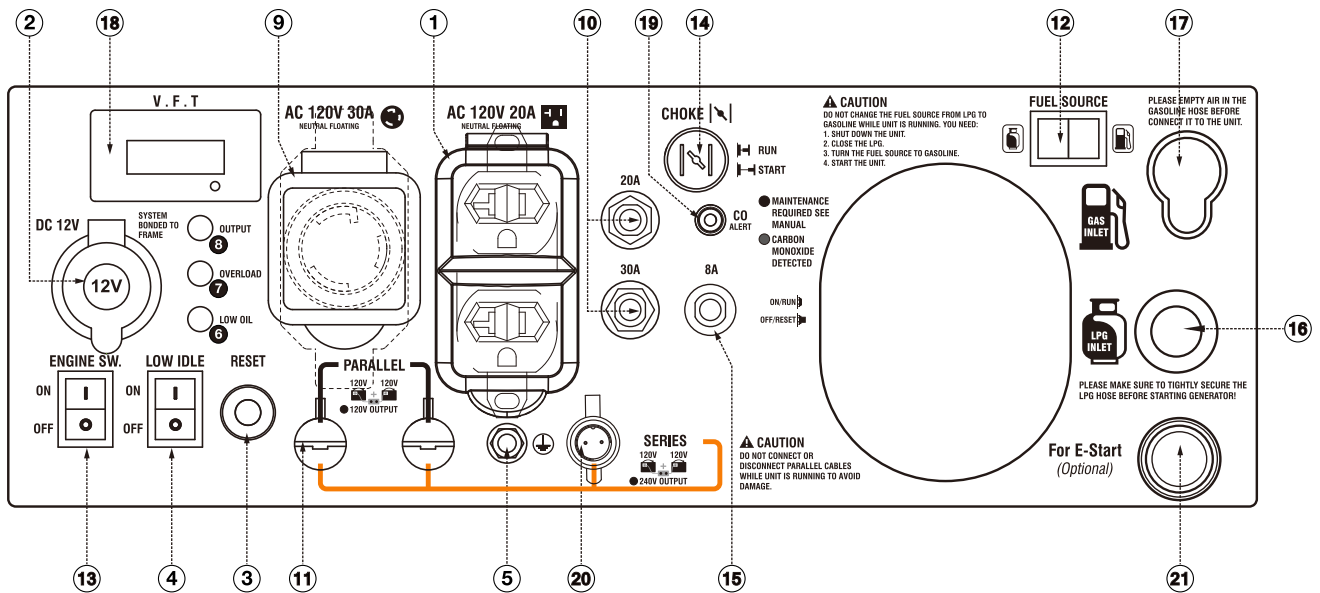

## CONTROL PANEL FEATURES GM4000XiD-NFT

- ① **120V AC 20A 5-20R Outlet:** The outlet is capable of carrying a maximum of 20 amps.
- ② **DC Cigarette Lighter Outlet:** 12V DC 8.3A.
- ③ **Reset:** If the inverter is overloaded, the reset breaker will trip. The engine will continue to run, but there will be no output from the inverter. Unplug the devices and reduce the load. Push in the reset breaker to reset it.
- ④ **Low Idle:** When turned to the ON position, the engine will sense the load needed and run at a slower RPM to save fuel.
- ⑤ **Ground Terminal:** The ground terminal is used to externally ground the inverter.
- ⑥ **Low Oil Alarm:** Indicates low oil level.
- ⑦ **Overload Alarm:** Indicates that the inverter is overloaded.
- ⑧ **Output Indicator:** Indicates the inverter is ready to be used.
- ⑨ **120V AC 30A L5-30R Outlet:** The outlet is capable of carrying a maximum of 30 amps.
- ⑩ **AC Protector:** If the generator is overload, the AC protector will trip to block current.
- ⑪ **Parallel Connectors:** To increase AC power output, the connector sockets are used to connect the two same type generators with special parallel kit GM6000SPK sold by GENMAX. The connector sockets is only used to connect two inverter generators. They can not used for AC power output. The special paralleling kit GM6000SPK shall be purchased separately, and they shall be approved by certification body.
- ⑫ **Fuel Source Switch:** Gasoline and LPG switch back and forth.
- ⑬ **Engine Switch:** Manage battery power and shutdown.
- ⑭ **Choke Switch:** when cold start, properly close part of the air inlet to improve the engine start performance, after normal operation, the choke should be fully open, otherwise the engine can not run properly because of too thick mixture and cause too much oil consumption.
- ⑮ **DC Protector:** If the generator is overload, the DC protector will trip to block current.
- ⑯ **LPG Hose Connection Port:** When LPG gas is used, install the dedicated LPG hose on the connection port.
- ⑰ **Fuel Hose Connection Port:** When using fuel, the special fuel tank hose should be installed in the connection port.
- ⑱ **Three in One Digital Display Table:** Voltage, frequency, time display, press the button to switch.
- ⑲ **CO Alarm:** Flashing red light: dangerous levels of carbon monoxide gas have built up leave immediately until area has aired out. Move generator to well-ventilated area before operation. Flashing yellow light: carbon monoxide sensor malfunction. Sensor needs service.
- ⑳ **Series Connectors (120/240V OUTPUT):** When using parallel kits, two 120V generators can output 240V by connecting this interface.
- ㉑ **For E-Start (Optional):** Hole reserved for electric start button.

# PREPARATIONS

## 1 Fuel

### **DANGER**

- Fuel is flammable and toxic, please read the Safety Instruction carefully before refueling;
- Do not fuel too full, otherwise fuel will spill after fuel tank is warmed;
- After refueling, confirm that the fuel tank cap has been tightened.

### **ATTENTION**

- After refueling, dry gasoline residue with a clean and soft cloth in time to avoid damaging plastic enclosure;
- Unleaded gasoline must be used, as leaded gasoline can seriously damage internal parts of the generator.

#### Connecting fuel tank

1. Connect the fuel tank connection hose to the fuel tank. The arrow identifier points to the side of the hose where the port connects to the fuel tank.



2. Connect the fuel tank connection hose to the generator. The arrow indicates that the outward interface is to be connected to the generator.

**Note:** When connecting the hose, make sure that the connector is clamped to the port of the panel and fuel tank. Hear a crisp sound to prove that it has been clamped.

3. Add appropriate amount of gasoline to the fuel tank.

**Note:** The tank should be placed higher than the engine.



#### Drain the air inside the tank connection hose

1. Press the hand pump 8-10 times continuously to let the gasoline in the tank enter the hose so that the gasoline fills the oil circuit of the generator.

**Note:** After each press of the hand pump, wait for the hand pump to return to its original state before performing the next compression (expected to recover within 2s).



2. Unplug the quick plug connected to the hose on the panel and connect the exhaust plug to the hose.

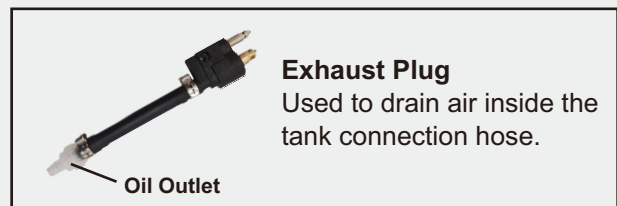

3. The oil outlet end of the exhaust plug is aligned with the fuel tank filler (*The purpose is to recover the gasoline in the hose and prevent it from flowing to the ground*), press the hand pump 5 times in a row, and after the air in the hose is completely discharged, unplug the exhaust plug and plug it back into the oil inlet on the panel.

# PREPARATIONS



**Tip:** Repeat step 2 and 3 after moving the tank halfway through or refueling the tank.

## **WARNING**

Do not place the oil outlet of the tank and the fuel hose on this side of the muffler, or the muffler may be dangerous when it heats up.

## **2** **LPG**

### **ATTENTION**

- Propane tanks that use liquid withdrawal system can not be used on these modes.
- Confirm that the re-qualification date on the tank has not expired.
- **DO NOT** use included LPG hose for any other appliances.
- All new propane tanks must be purged of air and moisture prior to filling. Used propane tanks that have not been plugged or kept closed must also be purged. The purging process should be done by a propane tank supplier (propane tanks from an exchange supplier should have been purged and filled properly).
- **ALWAYS** position the propane tank so the connection between the valve and the gas inlet will not cause sharp bends or kinks in the hose.

## **WARNING**

Explosion hazard. **DO NOT** start generator if you smell propane. **ALWAYS** fully close the propane tank valve and disconnect the LPG hose from the generator when not in use.

### **Connecting an LPG Tank**

1. Turn the generator OFF and place on a flat surface in a well ventilated area.
2. Verify that the LPG tank valve is in the fully closed position.
3. Connect the LPG hose to the LPG tank;

4. Tighten the other end of the LPG hose to the generator intake. Tighten the LPG hose connector with an adjustable wrench until it is snug. **DO NOT** overtighten.

**IMPORTANT: DO NOT use thread seal tape or any other type of sealant to seal the LPG hose connection.**



# PREPARATIONS

5. Turn the LPG tank valve to the fully open position. Check all connections for leaks by wetting the fittings with a solution of soap and water. Bubbles which appear or bubbles which grow indicate that a leak exists. If a leak exists at a fitting, turn the LPG tank valve to the fully closed position and tighten the fitting. Open the LPG tank valve and recheck the fitting with the soap and water solution. If the leak continues or if the leak is not at a fitting then DO NOT use the generator.



**Note: It is not recommended that the fuel tank and LPG be connected to the generator at the same time.**

## 3 Oil

No oil is filled into this generator when being delivered. Do not start up the generator without filling sufficient oil.

1. Please place the generator onto a horizontal plane surface;

2. Unscrew oil dipstick, Fill in 0.12gal (0.45L) oil (SAE 10W/30 oil is recommended, of which the grade is API standard Type SE or higher);

3. Tighten the oil dipstick.

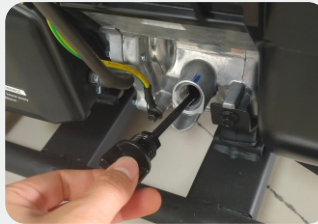

Don't go over the scale



## 4 Pre-use Inspection



### WARNING

Even if the generator is not in service, its important component may suddenly fails. Before the generator is started up, if any of following components is unable to work properly, please inspect and repair carefully.

**Tip:** The condition of the generator shall be inspected before using every time.

### Pre-operation inspection

#### Fuel

- Check fuel level in fuel tank of the generator, and fuel it if necessary.

#### Oil

- Check oil level of the generator, and fill oil if necessary;
- Check whether there is oil leaking.

### Abnormal conditions during operation

- Check operating condition of the generator;
- If there is any need, please do not hesitate to consult your dealer.

# STARTING UP THE GENERATOR

1. Remove the load from all output ends;

## 2. Select the Fuel:



a. Gasoline:

1. Connect the fuel tank. (See page 11 for connection steps)
2. Press fuel source switch to gasoline.



b. LPG:

1. Connect the LPG hose to the LPG tank. (See page 12 for connection steps)
2. Press the fuel source switch to LPG.



3. Press low idle switch to "OFF";



4. Press engine switch to "ON";

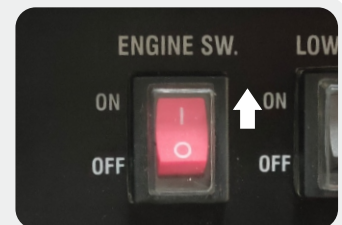

5. Pull the choke out;

**Tip:** There is no need to pull out the damper when the engine is started in warm state.



# STARTING UP THE GENERATOR

## 6. Select Boot Mode:

a. Hand Starting: First gently pull startup handle, until guy cable is hooked tight, and then pull it with effort.

**Tip:** When pulling the hand starter, hold generator carrying handle firm, to prevent the generator from overturning.

b. For E-Start: Press the one-click start button to start the generator.

**Tip:** This boot mode can only be selected if the electric boot function is installed.

OPTIONAL



## 7. After starting push the choke in.



## 8. Plug in after started.



## LPG startup is difficult ?

When both gasoline and propane are present in the generator it is recommended to start the generator on gasoline first, allow the engine to stabilize then switch to propane.

1. Ensure the LPG supply hose is securely attached and Close the LPG valve completely.



2. Fuel source rocker switch to gasoline.



3. Follow the startup steps to start the generator.

4. Open the LPG valve completely.



5. Fuel source switch to LPG.



**⚠ Note:** After successful LPG startup, unplug the fuel tank hose.



# SHUTTING DOWN THE GENERATOR

**1.** Unplug the power cord;

**2.** Set engine switch to "OFF" position.

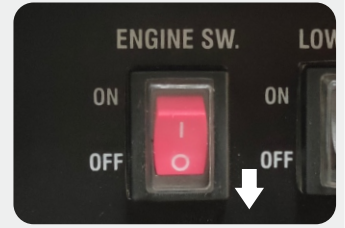

**3.** Remove gasoline tank hose (or LPG hose) and replace the dust cap.



# USING THE GENERATOR

## 1 Service Environment of the Generator

- Applicable temperature:  $-5^{\circ}\text{C} \sim 40^{\circ}\text{C}$ ;
- Applicable humidity: below 95%;
- Applicable altitude: regions below 1,500 m (It shall be used by reducing power in regions above 1,000 m).

### Standard atmospheric condition

- Ambient temperature  $T_r$ : 298k ( $25^{\circ}\text{C}$ )
- Relative air humidity  $\Phi_r$ : 30%
- Absolute atmospheric pressure  $P_r$ : 100kPa

**When actual environmental condition is inconsistent with the condition of output power of the generator set:**

- Every  $5^{\circ}\text{C}$  of increase in ambient temperature will reduce the power of generator by about 2%.
- Every 30% of increase in relative humidity of air will reduce the power of generator by about 1.5%.
- Every 300 m rising of ASL will reduce the power the generator by about 4.5%.

## 2 Generator Wiring

- When the generator is connected to household power source as a backup power supply, the connection shall be carried out by a professional electrician or a person familiar with electricity.
- After connecting the load to the generator, check carefully whether electrical connection is safe and reliable. Improper electrical connection may cause generator damage, burning or fire.
- Avoid connecting this generator to commercial power outlet.
- When extending the cable, be sure not to exceed its length.
  - ① 60m cross-section area is  $1.5\text{mm}^2$
  - ② 100m cross-section area is  $2.5\text{mm}^2$
- The appearance of extension cable shall be protected by a layer of tough and elastic rubber cover (IEC25) or other substitutes.

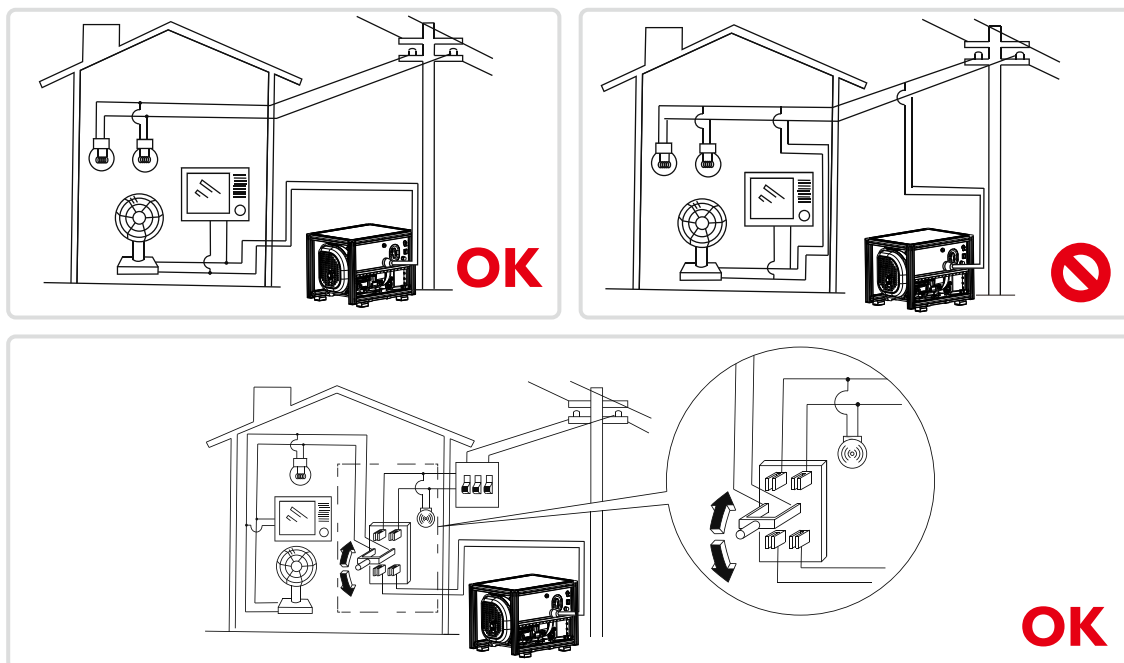

# USING THE GENERATOR

## Connection of AC power

### **WARNING**

All electrical equipment shall be disconnected before inserting the plug.

### **ATTENTION**

- Make sure that all electrical equipment, including wires and plugs, are in good condition before connecting to the generator;
- Make sure that all loads driven by the generator are within rated load range;
- Make sure that load current is within rated current range of rated socket.

**Tip:** Make sure that the generator set is grounded, and if electrical equipment requires grounding, the generator set must be grounded.

- ① Start up the engine;
- ② Turn energy-saving switch to "ON";
- ③ Insert the plug into AC outlet;
- ④ Make sure that AC indicator is lit up;
- ⑤ Switch on electrical equipment.

**Tip:** Before increasing engine speed, energy-saving switch must be switched to "OFF". If the generator set supplies power to multi loads or electrical equipment, start from large to small according to the size of each electrical equipment.

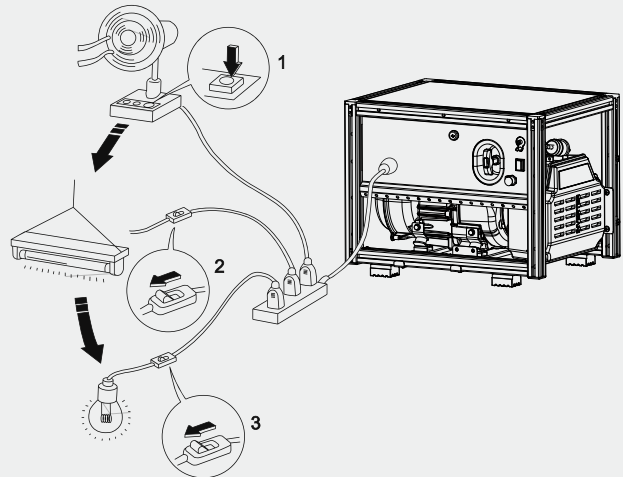

## **3** Generator Grounding

In order to prevent any damage to the generator caused by electric shock or improper electrical application, it is recommended that the generator is grounded with good conductor with insulating sheath.

- ① Please use grounding wire with sufficient electrical energy capacity;
- ② Connect one end of grounding wire reliable to grounding bolt on control panel of the generator set;
- ③ Insert grounding body (iron rod with a diameter of 5 ~ 10mm) 200mm below into the earth and lead it out with conductor;
- ④ Connect the other end of the grounding wire reliable to the led wire of grounding body.



**Tip:** How to change the grounding method please refer to the website: <https://www.genmaxpower.com/page/faq>

# USING THE GENERATOR

## 4 Parallel and Series Operation

To increase AC power output, the connector sockets are used to connect the two same type generators with special parallel kit GM6000SPK sold by GENMAX. The connector sockets is only used to connect two inverter generators. They can not used for AC power output. The special paralleling kit GM6000SPK shall be purchased separately, and they shall be approved by certification body. Follow the instructions included with your parallel connection kit for proper installation and operation.

**Parallel Connectors (120V OUTPUT):** Connect the parallel cables of connector (red) ① and connector (black) ② to the parallel ports of corresponding colors on the generator control panel; Connect the ground ring ③ to the generator ground terminal, and connect the other generator in the same way. Press the voltage selector switch to 120V ONLY.

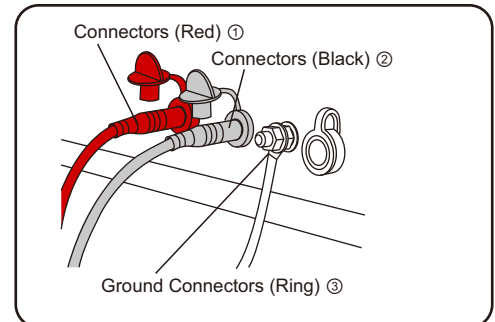

**Series Connectors (120/240V OUTPUT):** Connect the parallel cables of connector (red) ① and connector (black) ② to the parallel ports of corresponding colors on the generator control panel; Connect the ground ring ③ to the generator ground terminal; Connect the series connector ④ to the generator series connection port, and tighten the series connector nut. Connect the other generator in the same way. Press the voltage selector switch to 120/240V.

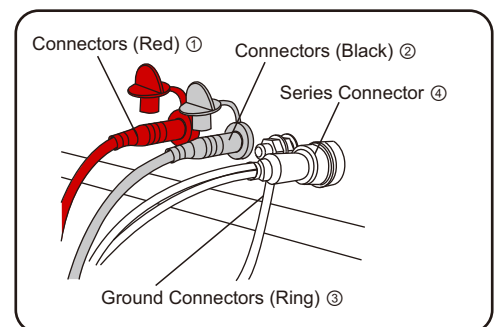

### **WARNING**

**TO PREVENT SERIOUS INJURY, DEATH, AND GENERATOR AND/OR EQUIPMENT DAMAGE FROM ELECTRIC SHOCK AND FIRE:**

1. Follow Parallel Kit instructions provided with Kit for connection and use of a Parallel Kit.
2. Only connect two identical Inverter Generators together using a Parallel Kit.
3. Connect Parallel Kit only to terminals marked "Parallel Outlets" on the front of the Generator.
4. Do not remove or connect a Parallel Kit while the Generator is running.
5. Do not use a Parallel Kit that is attached to only one Generator.

In parallel, the two generators should be connected to two fuel tanks. You cannot use the same tank to fuel two generators.

# SERVICE AND MAINTENANCE

Good maintenance and service is the best guarantee for safe, economical and zero-failure operation. It also contributes to environmental protection.

In order to keep the generator in good condition, you must inspect and maintain it regularly. The maintenance schedule is as follows:

Maintenance cycle		Item			
		Each	First in 1 month or 20 hours	Then every three months or every 50 hours	100 hours per year or use
Engine oil	Check-fill	√			
	Replace		√	√	
Gearbox gear Oil (if any)	Check oil	√			
	Replace		√	√	
Air cleaner element	Inspection	√			
	Clean		√		
	Replace			√	
Settling cup (if any)	Clean				√
Spark plug	Clean-adjust				√*
Spark eliminator	Clean			√	
Idle speed (if any)**	Check-adjust				√
Valve clearance**	Check-adjust				√
Fuel tank and fuel filter***	Clean				√
Fuel line	Inspection	Every two years (Please replace if necessary)			
Cylinder head, piston	Remove carbon deposit**	Displacement < 225cc, every 125 hours; displacement capacity ≥ 225cc, every 250 hours.			
<p>* These items shall be replaced if necessary;</p> <p>** These items shall be maintained by the dealer authorized by the Company, unless the user has proper tools and maintenance ability.</p>					

## ATTENTION

- If it often works under high temperature or high load, oil shall be changed every 25 hours;
- If it often works in dusty or harsh environment, air cleaner element shall be cleaned every 10 hours. If necessary, the air cleaner element shall be replaced every 25 hours;
- It shall be maintained on spot-inspection cycle and time, whichever is earlier;
- If maintenance cycle time has elapsed, perform the maintenance as soon as possible as per the table above.

# SERVICE AND MAINTENANCE

## **WARNING**

Please shut down the engine first before performing any maintenance. The engine shall be placed in a horizontal position. In order to prevent the engine from starting up, separate spark plug cap shall be separated from spark plug.

Do not use it indoors or use it in a tunnel, cave or other places ventilated poorly. Make sure that work area is well ventilated. Exhaust gas from the engine contains toxic gases, carbon oxides, and the inhalation can cause shock, loss of consciousness, and even death.

## **1 Spark Plug Inspection**

Spark plug is an important part of the generator, which must be inspected regularly.

1. Remove the high voltage assembly;



2. Insert the screwdriver into the sleeve, to screw it counterclockwise, and then remove the spark plug;

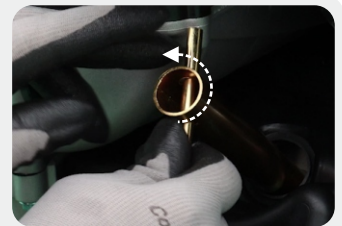

3. Check whether there is discoloration, and remove carbon deposits. Check whether there is little pale to moderate brown on ceramic cores around center electrode of the spark plug;



4. Check the model of spark plug and clearance.

**Spark plug gap: 0.7-0.8mm**

**Standard spark:**

BRAND	MODEL
NGK	C7HSA
	CR6HSA
TORCH	A5RTC



**Tip:** The spark plug clearance is required to be measured by line thickness gauge, which shall be adjusted if necessary.

# SERVICE AND MAINTENANCE

5. Install the spark plugs in reverse order of removal.  
**Spark plug torque:  $14\pm 1\text{N.m}$ ( $123.9\pm 8.8\text{in-lb}$ )**



**Tip:** If there is no torque wrench when installing the spark plug, a better estimation method is to screw it 1/4-1/2 turns by force after screwing it in place, but the spark plug shall be screwed to specified torque as soon as possible.

## 2 Adjustment of the Carburetor

The carburetor is an important components of the engine. The adjustment shall be carried out by a dealer with professional knowledge, professional data and equipment, to ensure that the adjustment is proper.

## 3 Replacement of Oil

### **WARNING**

**Do not drain the oil immediately after turning off the generator. Oil temperature is very high, when operating, take care to avoid scalding.**

1. Put the generator on a horizontal surface, start the generator, run it for a few minutes to increase its temperature, and then turn off the engine;

2. Unscrew oil dipstick;



3. Place the container and tilt the machine to drain the oil.

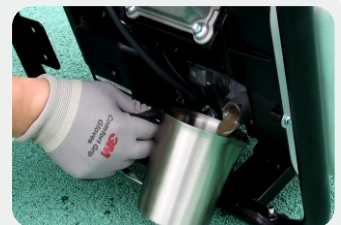

# SERVICE AND MAINTENANCE

4. Refill oil to a proper level, tighten oil dipstick, cover external cover plate and tighten the knob.

**Recommended oil: SAE S10W/30**

**Oil grade: API standard Model SJ or higher**  
**Volume: 0.12gal (0.45L)**

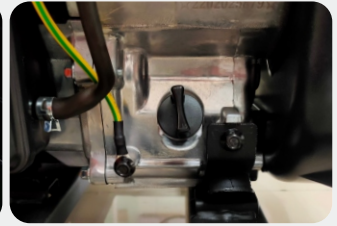

## 4 Air Filter

Dirty air cleaner may prevent air from flowing into the carburetor. In order to prevent failure of the carburetor, please maintain air cleaner regularly. If being used in a dusty environment, it shall be maintained frequently.

1. Remove screws, to remove cover plate of air cleaner ;

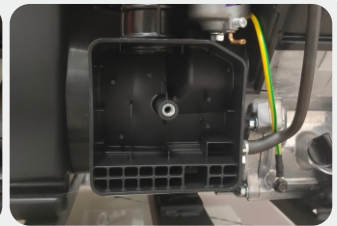

2. Clean foam cleaner element with cleaning solvent and blow it dry, Put a few drops of oil on the filter element;



### **ATTENTION**

**Be sure not to twist the foam cleaner element forcibly to avoid damage.**

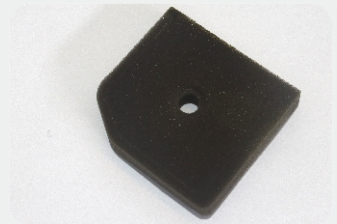

3. Put foam cleaner element into air cleaner;  
**Tip:** Make sure that the surface of foam cleaner element is in close contact with air cleaner, and there shall be no gap leaking air. Be sure not to start the engine before air cleaner is assembled, because it will generate excessive toxic gas and wear the cylinder;

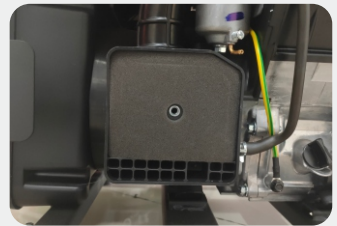

4. Reassemble empty air cleaner cap back to original position, and tighten screws.





# STORAGE AND TRANSPORT

## 1 Generator Storage

If it is stored long-term, in order to prevent aging, you shall take some storage measures.

1. Start up the engine to burn off fuel in the carburetor, and then shut it down.

**Tip:** Do not connect any electrical equipment. Running time of the engine depends on remaining fuel in the fuel tank.

2. Locate the carburetor nozzle, connect a hose or something else to drain the remaining gasoline, and place a suitable container under it to capture the discharged fuel.

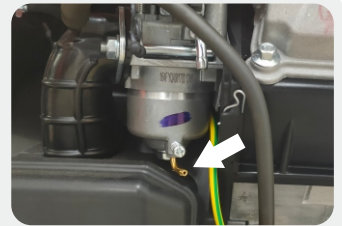

3. Loosen the carburetor drain screws until you see fuel draining from the carburetor.



4. Allow fuel to drain into the container and tighten the drain screws on the carburetor.



5. Unscrew oil dipstick, and drain oil in the crankcase off. Fill new oil to upper oil limit, and then assemble oil dipstick.

6. Gently pull startup handle until you feel resistance, allowing both inlet valve and exhaust valve to be closed.



7. Place the generator set in a clean and dry area.

## 2 Generator Transport

- When the generator set is transported, it shall be ensured that there is no fuel spilling;
- Do not fill excessive fuel into fuel tank;
- Do not run the generator, and avoid direct sunlight;
- Do not transport the generator set on rough road for long time.

# TROUBLESHOOTING

Problem	Possible Causes	Probable Solutions
Engine will not start	<b>FUEL RELATED:</b> <ol style="list-style-type: none"> <li>No fuel in tank or fuel valve closed.</li> <li>Choke not in START position, cold engine.</li> <li>Gasoline with more than 10% ethanol used. (E15, E20, E85, etc.)</li> <li>Low quality or deteriorated, old gasoline.</li> <li>Carburetor not primed.</li> <li>Dirty fuel passageways.</li> <li>Carburetor needle stuck. Fuel can be smelled in the air.</li> <li>Too much fuel in chamber. This can be caused by the carburetor needle sticking.</li> <li>Clogged Fuel Filter.</li> </ol>	<b>FUEL RELATED:</b> <ol style="list-style-type: none"> <li>Fill fuel tank with fresh 87+ octane stabilizer-treated unleaded gasoline and open fuel valve. <b>Do not use gasoline with more than 10% ethanol (E15, E20, E85, etc.).</b></li> <li>Move Choke to START position.</li> <li>Clean out ethanol rich gasoline from fuel system. Replace components damaged by ethanol. Use fresh 87+ octane stabilizer-treated unleaded gasoline only. <b>Do not use gasoline with more than 10% ethanol (E15, E20, E85, etc.).</b></li> <li>Use fresh 87+ octane stabilizer-treated unleaded gasoline. <b>Do not use gasoline with more than 10% ethanol (E15, E20, E85, etc.).</b></li> <li>Pull on Starter Handle to prime.</li> <li>Clean out passageways using fuel additive. Heavy deposits may require further cleaning.</li> <li><b>Gently</b> tap side of carburetor float chamber with screwdriver handle.</li> <li>Turn Choke to RUN position. Remove spark plug and pull the start handle several times to air out the chamber. Reinstall spark plug and set Choke to START position.</li> <li>Replace Fuel Filter.</li> </ol>
	<b>IGNITION (SPARK) RELATED:</b> <ol style="list-style-type: none"> <li>Power Switch at OFF position.</li> <li>Spark plug cap not connected securely.</li> <li>Spark plug electrode wet or dirty.</li> <li>Incorrect spark plug gap.</li> <li>Spark plug cap broken.</li> <li>Circuit breaker tripped (electric start models only).</li> <li>Incorrect spark timing or faulty ignition system.</li> </ol>	<b>IGNITION (SPARK) RELATED:</b> <ol style="list-style-type: none"> <li>Turn Power Switch to ON.</li> <li>Connect spark plug cap properly.</li> <li>Clean spark plug.</li> <li>Correct spark plug gap.</li> <li>Replace spark plug cap.</li> <li>Reset circuit breaker. Check wiring and starter motor if breaker continues to trip.</li> <li>Have qualified technician diagnose/repair ignition system.</li> </ol>
	<b>COMPRESSION RELATED:</b> <ol style="list-style-type: none"> <li>Cylinder not lubricated. Problem after long storage periods.</li> <li>Loose or broken spark plug. (Hissing noise will occur when trying to start.)</li> <li>Loose cylinder head or damaged head gasket. (Hissing noise will occur when trying to start.)</li> <li>Engine valves or tappets mis-adjusted or stuck.</li> </ol>	<b>COMPRESSION RELATED:</b> <ol style="list-style-type: none"> <li>Pour tablespoon of oil into spark plug hole. Crank engine a few times and try to start again.</li> <li>Tighten spark plug. If that does not work, replace spark plug. If problem persists, may have head gasket problem, see #3.</li> <li>Tighten head. If that does not remedy problem, replace head gasket.</li> <li>Have qualified technician adjust/repair valves and tappets.</li> </ol>
	<b>ENGINE OIL RELATED:</b> <ol style="list-style-type: none"> <li>Low engine oil.</li> <li>Engine mounted on slope, triggering low oil shutdown.</li> </ol>	<b>ENGINE OIL RELATED:</b> <ol style="list-style-type: none"> <li>Fill engine oil to proper level. Check engine oil before EVERY use.</li> <li>Operate engine on level surface. Check engine oil level.</li> </ol>
	<b>SPARK ARRESTOR RELATED:</b> <ol style="list-style-type: none"> <li>Spark Arrestor clogged with soot.</li> </ol>	<b>SPARK ARRESTOR RELATED:</b> <ol style="list-style-type: none"> <li>Clean and replace Spark Arrestor.</li> </ol>



**Follow all safety precautions whenever diagnosing or servicing the generator or engine.**

# TROUBLESHOOTING

Problem	Possible Causes	Probable Solutions
Engine misfires	<ol style="list-style-type: none"> <li>1. Spark plug cap loose.</li> <li>2. Incorrect spark plug gap or damaged spark plug.</li> <li>3. Defective spark plug cap.</li> <li>4. Old or low quality gasoline.</li> <li>5. Incorrect compression.</li> </ol>	<ol style="list-style-type: none"> <li>1. Check cap and wire connections.</li> <li>2. Re-gap or replace spark plug.</li> <li>3. Replace spark plug cap.</li> <li>4. Use only fresh 87+ octane stabilizer-treated unleaded gasoline. <b>Do not use gasoline with more than 10% ethanol (E15, E20, E85, etc.).</b></li> <li>5. Diagnose and repair compression. (Use <b>Engine will not start: COMPRESSION RELATED</b> section.)</li> </ol>
Engine stops suddenly	<ol style="list-style-type: none"> <li>1. Carbon Monoxide level high. Red light on Carbon Monoxide Sensor illuminates.</li> <li>2. CO Sensor Alarm flashes yellow continually shortly after starting.</li> <li>3. CO Sensor Alarm flashes yellow continually after longer period of operation.</li> <li>4. Low oil shutdown.</li> <li>5. Fuel tank empty or full of impure or low quality gasoline.</li> <li>6. Defective fuel tank cap creating vacuum, preventing proper fuel flow.</li> <li>7. Faulty magneto.</li> <li>8. Disconnected or improperly connected spark plug cap.</li> </ol>	<ol style="list-style-type: none"> <li>1. Leave area immediately and allow area to ventilate thoroughly. Only operate generator outside.</li> <li>2. Carbon monoxide sensor malfunction. Sensor needs service. Do not use the Generator until the sensor is working properly.</li> <li>3. Make sure to operate generator within rated ambient temperature; maintain minimum 5 ft. clearance from all sides.</li> <li>4. Fill engine oil to proper level. Check engine oil before EVERY use.</li> <li>5. Fill fuel tank with fresh 87+ octane stabilizer treated unleaded gasoline. Do not use gasoline with more than 10% ethanol (E15, E20, E85, etc.).</li> <li>6. Test/replace fuel tank cap.</li> <li>7. Have qualified technician service magneto.</li> <li>8. Secure spark plug cap.</li> </ol>
Engine stops when under heavy load	<ol style="list-style-type: none"> <li>1. Dirty air filter</li> <li>2. Engine running cold.</li> </ol>	<ol style="list-style-type: none"> <li>1. Clean element.</li> <li>2. Allow engine to warm up prior to operating equipment.</li> </ol>
Engine knocks	<ol style="list-style-type: none"> <li>1. Old or low quality gasoline.</li> <li>2. Engine overloaded.</li> <li>3. Incorrect spark timing, deposit buildup, worn engine, or other mechanical problems.</li> </ol>	<ol style="list-style-type: none"> <li>1. Fill fuel tank with fresh 87+ octane stabilizer-treated unleaded gasoline. <b>Do not use gasoline with more than 10% ethanol (E15, E20, E85, etc.).</b></li> <li>2. Do not exceed equipment's load rating.</li> <li>3. Have qualified technician diagnose and service engine.</li> </ol>
Engine backfires	<ol style="list-style-type: none"> <li>1. Impure or low quality gasoline.</li> <li>2. Engine too cold.</li> <li>3. Intake valve stuck or overheated engine.</li> <li>4. Incorrect timing.</li> </ol>	<ol style="list-style-type: none"> <li>1. Fill fuel tank with fresh 87+ octane stabilizer-treated unleaded gasoline. <b>Do not use gasoline with more than 10% ethanol (E15, E20, E85, etc.).</b></li> <li>2. Use cold weather fuel and oil additives to prevent backfiring.</li> <li>3. Have qualified technician diagnose and service engine.</li> <li>4. Check engine timing.</li> </ol>
Attached device doesn't have power	<ol style="list-style-type: none"> <li>1. Device not plugged in properly.</li> <li>2. Circuit Breaker tripped.</li> <li>3. Product needs service.</li> </ol>	<ol style="list-style-type: none"> <li>1. Turn off and unplug the device, then plug it back in again and turn on.</li> <li>2. Turn off and unplug device, reset Circuit Breaker, plug in device and turn on.</li> <li>3. Have product repaired.</li> </ol>
Attached device begins to operate abnormally	<ol style="list-style-type: none"> <li>1. Problem with device.</li> <li>2. Rated load capacity exceeded.</li> </ol>	<ol style="list-style-type: none"> <li>1. Immediately unplug device. Have device repaired by a qualified technician, or replace device.</li> <li>2. Lower the number of items plugged into the generator to stay within the rated capacity, or use a more powerful generator.</li> </ol>



**Follow all safety precautions whenever diagnosing or servicing the generator or engine.**

## TECHNICAL PARAMETERS

Item	GM4000XiD-NFT
Rated Power (kW)	3.2(GAS.)/3.0(LPG)
Max. Power (kW)	4.0(GAS.)/3.8(LPG)
Engine Model	164F/P-2
Valve Clearance	Input valve:0.03~0.08mm, Output valve:0.03~0.08mm
Stroke x Bore (mm)	64x45
Engine Type	4-stroke
Displacement (cc)	145
Gas Distribution Mode	OHV
Cooling Mode	Forced cooling wind
Rated Speed (RPM)	4850
Starting Method	Recoil start
Fuel Type and Grade	Vehicle-use unleaded gasoline
Lubricating Oil Capacity (gal)	0.12 (0.45L)
Lubricating Oil Model	SAE 10W/30
Noise dB (at 7m)(25% load)	65
Rated Voltage (V)	120
Rated Frequency (Hz)	60
Rated Power Factor	1
Phase Number	Single phase
Run Time @ 25% (h)	Depends on the fuel tank volume
Fuel Consumption Rate (25% load)(L/h)	0.64
Fuel Consumption Rate (100% load)(L/h)	1.79
LPG Consumption Rate (25% load)(kg/h)	0.45
LPG Consumption Rate (100% load)(kg/h)	0.9
THD	≤5%
Overall Dimension (in.)	18.8×14.5×14.8 (480x370x376mm)
Net Weight (lb.)	58.4 (26.5kg)

# CIRCUIT DIAGRAM

## GM4000XiD-NFT SCHEMATICS

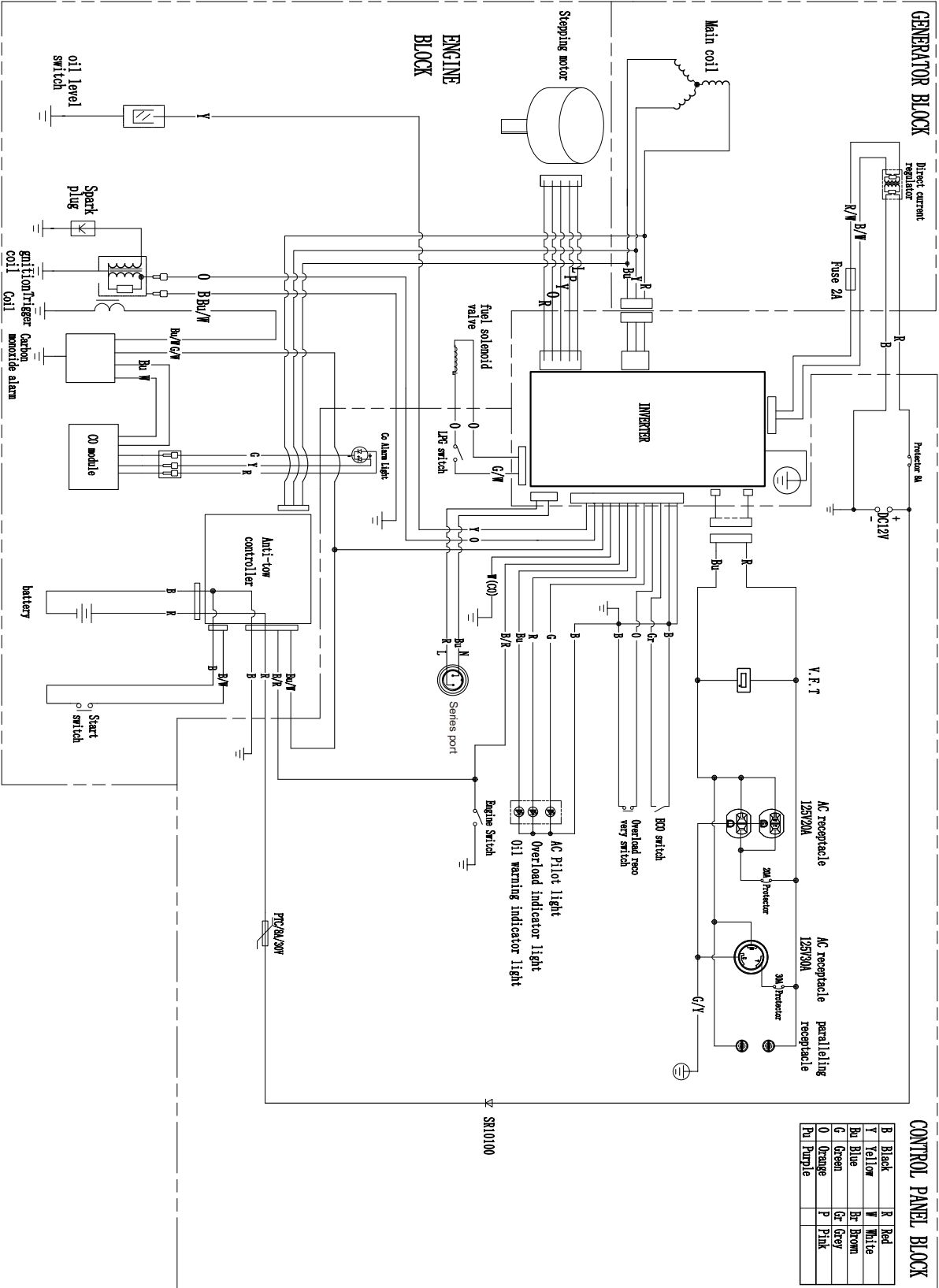

## QUICK REFERENCE WATTAGE

Power Rating	Tool or Appliance	Running Watts	Starting Watts	
<b>5500 - 12,000</b> Running Watts	<b>1200 - 1800</b> Running Watts	Blender	300	650
		Coffee Maker	1500	
		Drill	600	900
		Fan	200	
		Furnace 1/4 hp	600	1000
		Game console	150	
		Hand sander	600	1200
		Hedge trimmer	450	1200
		Lamp	100	
		Laptop	800	
		LED/LCD TV	150	
		Microwave	1000	
	Modem/router	20		
	Paint sprayer	600	600	
	Radio	100		
	Slow cooker	200	200	
	String trimmer	350	875	
	Sump Pump 1/3 hp	800	1300	
	Work light	1000		
	<b>2800 - 3800</b> Running Watts	Belt sander	1200	2400
Chainsaw		1200	2400	
Circular saw		1200	2000	
Edger		950	2400	
Electric grill		1650		
Lawn mower		1200	2400	
Pressure washer		1200	2400	
Refrigerator		700	2200	
Washing machine		1150	2250	
Well pump		1000	2100	
Window AC 13k BTU		1800	2800	
Air compressor 1 hp		1600	4500	
Central AC 3 ton		5400	7200	
Electric Dryer		5400	6750	
Heat Pump 3 ton		3400	6500	
Water heater		4000		

†Chart for reference only. Check your device for ACTUAL wattage requirements.

## HOW TO CALCULATE

### Running Watts needed:

Total Running Watts of ALL items to be powered by the generator.

### Starting Watts needed:

Add highest SINGLE Starting Watt to Total Running Watts needed above.

## EXAMPLE

### 1 Calculate Running Watts:

Furnace	600
Lamp	100
Microwave	1000
Refrigerator	700
<b>Total Running Watts</b>	<b>2400</b>

### 2 Calculate Starting Watts:

Total Running Wattage	2400
Refrigerator	2200
<b>Total Starting Watts</b>	<b>4600</b>



# OPTIONAL

Choose the features you need to upgrade your generator, you can use any combination.

<p><b>Wheel and Telescopic Rod</b> Make it easier to move around.</p>	 
<p><b>Toolbox</b> It can be used to store tools that may be used by the generator, such as spark plug socket wrench, dual-purpose screwdriver, and LPG hose.</p>	
<p><b>Electric Start</b> Button start, more easy and simple.</p>	 
<p><b>Series and Parallel Kit</b> 2 sets of GENMAX 120V inverter generators are connected in series with our special series-parallel box to realize the conversion of 120V to 240V output, so as to achieve changeable usage scenarios and double the power.</p>	  
<p><b>Fuel Tank</b> It can store 14.5L gasoline and connect the fuel hose to fuel the generator.</p>	 

For more information about Optional features, please refer to: [Http://www.genmaxpower.com](http://www.genmaxpower.com)



In production management, based on orderly, efficient, scientific principles. trying to do as better as possible in product design, development, production, inspection, etc. to make our production can keep orderly. And will continue to make improvement to make sure that keep the competitiveness.

**Welcome friends at home and abroad to visit and guide, work together to create brilliant.**

# GENMAX<sup>®</sup>

**Caojie Industrial Park, Hechuan District, Chongqing**

**Phone** 866-960-2920

**E-mail** [service@genmaxpower.com](mailto:service@genmaxpower.com)

**Http://**[www.genmaxpower.com](http://www.genmaxpower.com)



Facebook



LinkedIn



YouTube

