

GENMAX[®]

USER MANUAL



Thank you for purchasing
MP330/MP500
PORTABLE POWER STATION



CHARGE FIRST

Before using your new Power Station, plug it into a suitable power outlet until it is fully charged, then you can start your exciting journey with it.

Thank you for purchasing MP series portable power station, To make sure your personal safety, property security and user experience, please read this manual carefully before operating, and retain it for future reference.

TABLE OF CONTENTS

1. GENERAL SAFETY RULES -----	P02
2. SPECIFICATIONS -----	P03
3. INPUTS AND OUTLETS -----	P05
4. BUTTON CONTROLS -----	P06
5. LCD DISPLAY -----	P07
6. OPERATION -----	P08
7. WHAT IT POWERS -----	P08
8. HOW TO CHARGE -----	P09
9. FAQs -----	P11
10. TROUBLE SHOOTING -----	P12
11. FCC STATEMENT -----	P14
12. NOTICE -----	P14
13. ACCESSORY LIST -----	P14
14. LIMITED WARRANTY -----	P15

GENERAL SAFETY RULES

WARNING

Read this manual before using this product. Failure to follow the instructions and safety precautions in this manual can result in damage to the product or personal property, or serious injury or death. DO NOT use the product with incompatible components or alter the product in any way.

WARNING

Improper use may result in fire, property damage, or personal injury. Make sure to use the product according to the following safety rules and guidelines.

WARNING

Do not expose the product to any liquid or submerge in water. If the battery comes into contact with water, it may cause chemical decomposition of the battery. This may cause the battery to catch fire or explode.

SAFETY INSTRUCTIONS

Read the following instructions to ensure safe usage:

 **DANGER**
Noncompliance may very likely lead to serious injury* or death-

- DO NOT disassemble, repair or modify the unit or the battery.
- DO NOT place the unit close to or in a fire or expose it to heat. Keep out of direct sunlight.
- DO NOT charge, use or store the unit in a bathroom or in an area exposed to rain or moisture.
- Only use the output socket to power external devices. Never connect the output to mains power under any circumstances.
- DO NOT touch the unit or the plug-in points if your hands are wet.
- DO NOT connect any metallic objects to the AC input or output.
- DO NOT rub your eyes if fluid from inside the unit should get in your eyes.
- DO NOT dispose the unit together with household waste.
- DO NOT use any inappropriate power cords.
- DO NOT operate the unit above the specified input voltage.
- DO NOT use the unit if it is not functioning correct
- DO NOT move the unit if it is recharging or in use.

 **WARNING**
Noncompliance may lead to serious injury** or death

- Use and store the unit only in a clean and dry environment. Do not use and store in dusty and wet environment.
- Check the unit prior to every use. Do not use the unit if it is damaged, broken.
- DO not use the unit if the power cord is damaged or broken.
- Keep the unit away from children. DO NOT let children use the power supply unit.
- Keep this product away from pets.
- DO NOT use or store the unit in an area or environment with high temperature.
- Should fluid from inside of the unit come in contact with your skin or clothing, wash the affected areas with tap water.
- In a storm, unplug the power cord from the socket.
- DO NOT charge the unit via power supply systems that operate outside of 100~240V.
- DO NOT place the unit on its side or upside down while in use or storage.
- DO NOT use accessories for other usage.

 **CAUTION**
Noncompliance may lead to injuries and/or property damage**

- If rust peculiar odors, overheating or other abnormal circumstances are observed, stop using the unit immediately and contact the dealer or our customer service center.
- The unit complies with all legal requirements for transport of dangerous goods.
- Make sure that the unit is properly secured when transporting it in a motor vehicle.
- Only charge, use and store the unit within an ambient temperature of 0 to 40°C (32 ~104°F).
- Switch the unit off immediately if it has accidentally fallen, was dropped or was exposed to vibrations.
- Once the unit is fully charged, unplug the adapter or charger. Wattbricks is not liable for any damage caused by using different brand charging cables.
- Use of different cables will void the products warranty and may cause damage or serious bodily injury.

Carefully read the instructions for the electric devices that you intend to connect to your power.

Product Maintenance:

- 1) Battery life may be reduced or become nonfunctional if not properly maintained.
- 2) Fully charge and discharge the battery at least once every 3 months to maintain battery health.
- 3) Do not store battery with less than 50% charge.

SPECIFICATIONS

Model Name:	Mp330
Battery Cell Chemistry:	Lithium Ion (Li-ion) NMC
Capacity:	288.6Wh 11.1V 26Ah
Running Watts:	330W
Surge Peak:	700W
AC Output Voltage:	110V
Frequency:	60Hz
Waves Type:	Pure Sine Waves
Wireless Charger	5W
Life Cycle:	800 Cycles to 60% Capacity
Charge Time:	With Adapter charger: 0-100% charge 6-8 hours; With car charger: 0-100% charge 6-8 hours; With solar charger(60W): 0-100% charge 6-8 hours
Charging Temperature Range:	32° – 104°F (0° – 40°C)
Operational Temperature Range:	5° – 113°F (-15° – 45°C)
Warranty:	1 Year
Certifications:	FCC, RoHS, UN38.3

INTENDED USE

The Wattbricks Power Station is intended as a power supply for electronic devices with a maximum power consumption of continuous wattage. Our product is not suitable to be used with equipment that relates to one's own personal safety and relies heavily on electricity, such as medical devices, equipment for nuclear facilities, the manufacture of air and spacecraft, etc. We therefore assume no liability for accidents involving personal safety, fires, or machine failures caused by using our product with the aforementioned devices.

SPECIFICATIONS

Model Name:	MP500
Battery Cell Chemistry:	Lithium Ion (Li-ion) NMC
Capacity:	519.48Wh (22.2V, 23.4Ah)
Running Watts:	500W
Surge Peak:	1000W
AC Output Voltage:	110V
Frequency:	60Hz
Waves Type:	Pure Sine Waves
Wireless Charger	10W
Life Cycle:	800 Cycles to 60% Capacity
Charge Time:	With Adapter charger: 0-100% charge 6-7 hours; With car charger: 0-100% charge 7-8 hours; With solar charger(100W): 0-100% charge 7-9 hours
Charging Temperature Range:	32° – 104°F (0° – 40°C)
Operational Temperature Range:	5° – 113°F (-15° – 45°C)
Warranty:	1 Year
Certifications:	FCC, RoHS, UN38.3

INTENDED USE

The Power Station is intended as a power supply for electronic devices with a maximum power consumption of continuous wattage. Our product is not suitable to be used with equipment that relates to one's own personal safety and relies heavily on electricity, such as medical devices, equipment for nuclear facilities, the manufacture of air and spacecraft, etc. We therefore assume no liability for accidents involving personal safety, fires, or machine failures caused by using our product with the aforementioned devices.

INPUTS AND OUTLETS

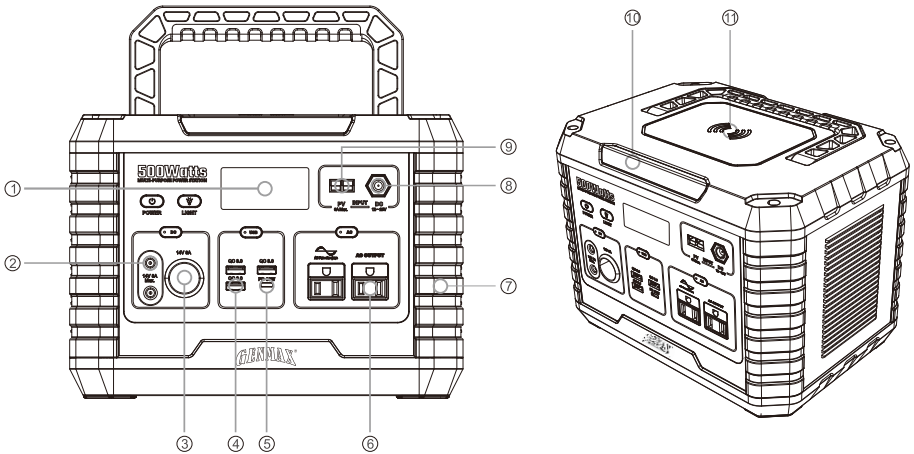

- | | | |
|----------------------------|------------------------|------------------------|
| ① LCD Screen Display | ⑤ USB-C Output | ⑨ PV Input |
| ② DC 5525 Output | ⑥ AC Output | ⑩ SOS MODE & LED light |
| ③ Cigarette Lighter Output | ⑦ Anti-collision Strip | ⑪ Wireless Charger |
| ④ USB-A Output | ⑧ DC Input | |

1. LCD Display

Displays the various conditions of the product. The screen will turn off after 5 mins. You can turn it on by pressing ON/OFF button.

2. USB-A Output Ports

Charge a wide array of devices such as your iPhone, tablet, GoPro, speakers, or anything that needs to be charged through a USB-A Port. The USB-A Output Indicator Light will automatically light up when a USB-A port is in use.

3. USB-C Output Ports

Devices that charge through a USB-C port, such as a MacBook Pro, Android phone, or other devices can be charged by the MP500 USB-C port. The USB-C Output icon will appear on LCD Display when a USB port is in use.

4. DC input

Charging the unit by the DC input, there are three ways for charging: solar PV input, charger input, and the adapter input.

5. PV input

It is an Anderson port, the unit can be charged by the solar PV panel with Anderson plug.

BUTTON CONTROLS

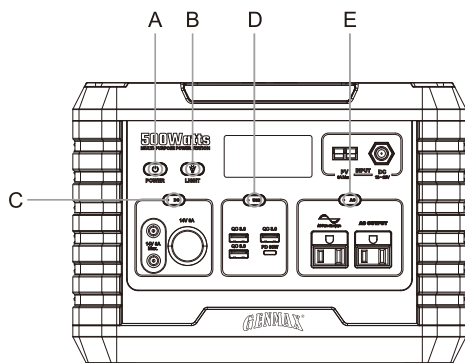

- A: MAIN POWER
- B: LED LIGHT ON/OFF
- C: DC ON/OFF Button
- D: USB ON/OFF Button
- E: AC ON/OFF Button

Button A: MAIN POWER

Button A is the main power switch. Press Button A to turn on or off

Button B: LED LIGHT ON/OFF

Activates:

Single Press - Turn on/off LED light on back of unit

Double Tap - Activate SOS Mode, LED light visual distress signal.

Button C: DC OUT ON/OFF

Please Press Button C to activate the DC out plug(s) after turning on the Main Power (A).

Button D: USB OUT ON/OFF

Please Press Button D to activate the USB out plug(s) after turning on the Main Power (A).

The USB-C cable of different devices need different endorsements of corresponding protocols, if the USB-C port doesn't work, try to use the AC adapter to charge .

Button E: AC OUT ON/OFF

Press Button E to Activate the AC out plug(s) after turning on the Main Power (A).

Please turn off the AC Out Plug(s) when not in use.

Note: The Fan may turn on intermittently during high output loads or temperatures.

Wattage Limit Please observe the wattage limit on the AC OUT.

Wireless charger

MP500: Press Main Power (A) to turn on or off the wireless charger.

Cooling fan

Product utilizes an internal cooling fan to ensure the product is operating within the appropriate temperature range. MP500, when it experiences a higher output load, will automatically turn on the fan during discharge or recharging , the fan may operate intermittently to keep internal temperature within operating range.

The fan will likely start when the AC circuit is activated to ensure proper operation.

LCD DISPLAY

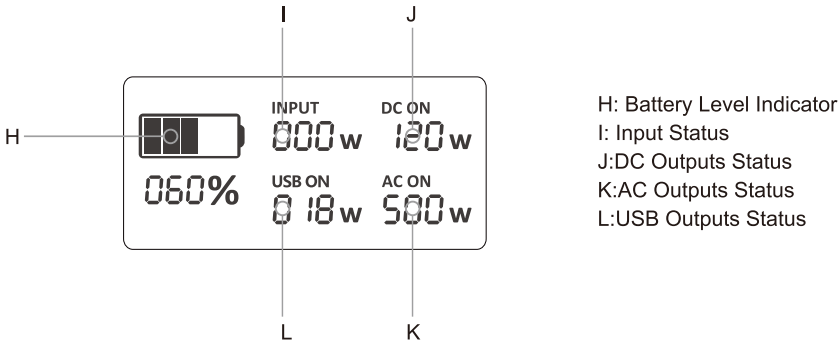

Battery level indicator

The battery level is provided by percentage of battery charge corresponding to the number of bars and percentage displayed. The segments in the battery level correspond to the current state of charge, 0-5% empty, 6-20% one segment, 21-40% two segments, 41-60% three segments, 61-80% four segments, and all five are lit when charge level is above 81%.

Provides the user live telemetry data on time to completely charge, or deplete the battery based upon the energy entering or leaving the battery.

Highly recommend to fully charge product when first use. Higher battery level indicator show, more precise the data will indicate.

Please be aware that this value can adjust multiple times as the energy draw changes from the connected devices. This is evident during initial activation of ports with a connected device.

Recommended back to charge the product when battery indicate less than 20%. Note that when you first plug in a power source, whether it's a solar panel or a wall charger, the product may take a minute to detect and adjust its charge circuitry before it starts drawing power from the source.

Input status : The product is capable of providing input energy in watts.

DC output status : The display will provide output watts of the DC port.

AC output status : The display will provide output watts of the AC port.

USB output status : The display will provide output watts of the USB port.

Power-saving mode:

when the device enters the input or output state, it will enter the screen-off mode after more than 20 seconds, which does not affect the normal operation of the device. When the output power of the device is less than 5W, the device will go into hibernation after more than 3 hours, and the input can be "awakened" when the input is charged or any button is pressed. When not in use, press the switch button to turn off the output.

OPERATION

Only operate the Power Station within the recommended temperature range 14°–113°F (-10°–45°C). Do not move the unit if it is charging or in use.

How to power AC devices

Make sure the devices you are plugging in are turned off. Connect the power cable plug of the electrical device into an AC outlet on the Power Station. Push the AC ON/OFF button to turn on AC power. The button will illuminate when it is turned on. Turn ON the AC device. The LED Display will show the real-time wattage use of the device. When finished, turn off all attached devices, remove the power cable, then push the AC ON/OFF button to turn OFF AC power. (If you leave the AC ON/OFF button ON it will deplete the battery.)

NOTICE: If the total output exceeds running power, the power station will automatically shut off. Make sure the Power Station can supply enough continuous (running) and peak (starting) watts for the items you will power at the same time.

How to power DC or USB devices

Connect the power cable plug of the electrical device to a USB outlet or DC outlet. Push the DC ON/OFF or USB ON/OFF button to turn on. The button will illuminate when it is on. The LCD Display will display real-time wattage of the device. When finished, push the DC ON/OFF or USB ON/OFF button to turn off

NOTICE:

If the total output exceeds the wattage output of the DC outlet, the power station will automatically shut off. Ensure the power consumption is less than what the ports are rated before connecting them to the Power Station.

WHAT IT POWERS



Laptops (41.4Wh)



32" TV(60W)



CPAP without heated



GoPro (5.9Wh)



Floodlight(40W)



Mini Fridge(40W)



DJ Drone(89.2Wh)



Smartphone(10Wh)



Switch(16Wh)

+MORE

HOW TO CHARGE

CHARGING

Only charge the Power Station within the safe charging temperature range (32°–104°F (0°–40°C)). It is recommended to fully charge product every 3 months to maintain the health of the battery pack.

MP330

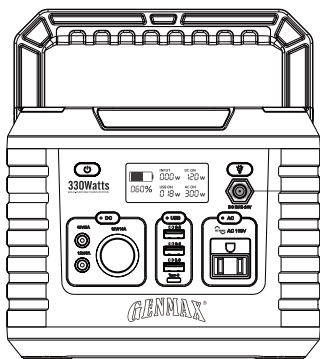

From Solar Charger
100W 6-8 hours
depending on solar conditions



From Car Port 12V
7-9 hours when car running



From Wall Charger 110V
6-7 hours

MP500

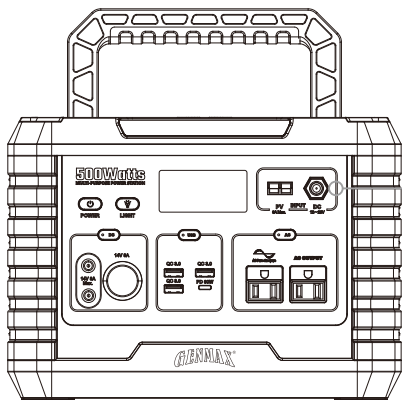

From Solar Charger
100W 7-9 hours
depending on solar conditions



From Car Port 12V
7-8 hours when car running



From Wall Charger 110V
6-7 hours



Caution: Only one kind of charge modes is allowed when charging. Do not charge the product with solar charger and adapter or car charger at the same time!

AC Adapter Charging

It will take 6-7 hours to charge fully by using the AC adapter we provided.

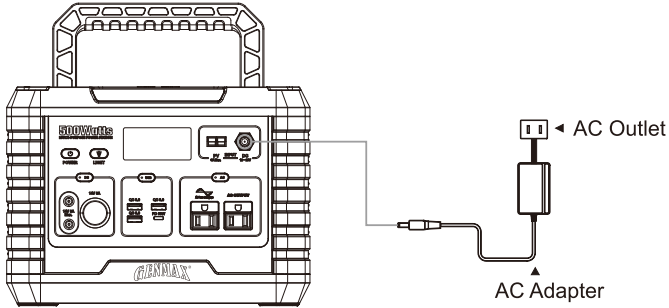

Solar Panel Charging

1. DO NOT charge the unit via solar panel that operate voltage outside of DC12-26V
2. Place Solar Panels in direct sunlight as much as possible.
3. Support 60W/80W/100W/120W Max Solar Panels (Not included), the charging time is determined by the solar light intensity.
4. Support DC7909 or anderson PV input ports

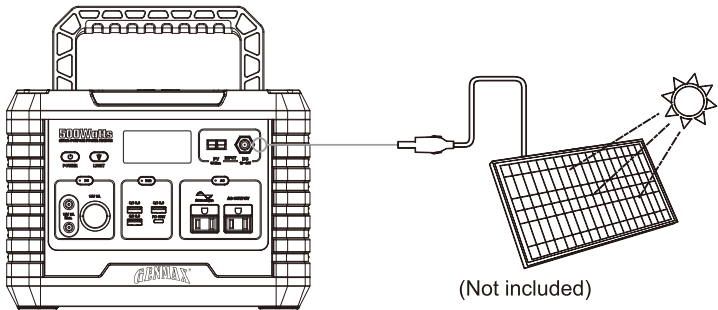

12V Car Charger Charging

Use the Car Charger we provided to charge this unit. The full charge time takes 7-8 hours. When the LCD display shows the battery power of 100%, it indicates that this unit is fully charged.

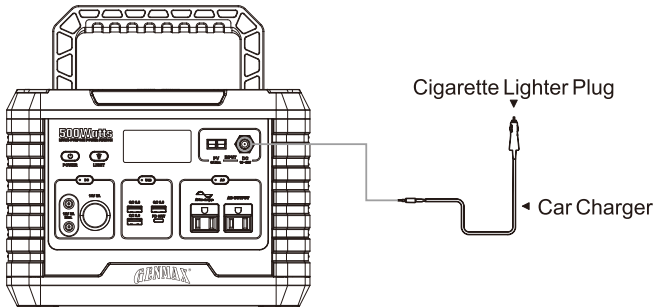

Caution: Do not charge the product with solar PV input and car port at the same time!



WARNING

Do not charge the Power Station immediately after it is fully discharged. For safety, wait 2 to 3 hours for the product to cool down before charging. If you attempt to charge product immediately after a full discharge, the product will display INPUT 0W on the LCD as an overheating protection reminder.

Can MP500 power my AC devices while it's charging?

NO, the advanced battery management system of the Mp500 allows it to charge a connected device via DC output & USB output while charge the product. Do not connected device via AC output while charging the Mp500 .

FAQs

Q: What devices can I charge and power with the product?

A: The AC output port is designed to charge/power devices that operate at less than continuous/running watts total. Devices drawing more than it cumulatively will not function.

Q: Can the product be charged during use?

A: While pass-through charging is supported, we do not suggest it. as it will diminish the long term battery life.

Q: For how many hours will MP500 power my device?

A: To calculate the working time use this formula: $500\text{Wh} \times 0.82 / \text{Watts of your device}$.
Example: 40 watt mini fridge: $500\text{Wh} \times 0.82 / 40 = \text{approx. 10 hours}$

Q: Is there a built-in MPPT controller?

A: Yes, all MPXXX portable power stations include a built-in MPPT controller.

Q: How do I check the current charge?

A: Turn the product on and refer to the Battery Level Status on the LCD Display.

Q: Why does charging From 99% to 100% take so long?

A: This is normal. To optimize battery life and charging speed, the battery charges faster when it is low, and as it approaches the maximum charge (100%), the unit will automatically limit the charging speed to avoid damage to the battery.

Q: Can I leave the product plugged in and charging all the time?

A: No, Once the unit is fully charged, unplug the adapter or charger.

Q: Are the output ports regulated?

A: Yes all outputs are regulated to minimize voltage change as the battery power decreases.

Q: Can I replace the internal battery?

A: No, never disassemble or modify the product. Always follow your local laws for proper battery disposal and/or recycling.

Q: My AC device is rated for less than the rated wattage of the product, but my device won't turn on when plugged into the AC port.

A: Certain devices require more wattage upon startup than may be listed on the device.

If the startup wattage of the device exceeds the rated/continuous wattage of the product, the device will not turn on, even if the wattage listed on the device is less than listed on the product. In this case, verify the AC port is working by trying a lower wattage device

TROUBLE SHOOTING

The device does not discharge:

- (1) Check whether the output buttons are activated ;
- (2) Check whether the total output power exceeds the rated output power;
- (3) Check whether the temperature of the equipment is too high.

The device can not be charged:

- 1) Confirm that the wall plug power adapter's cord is inserted fully into the DC Input.
- 2) Confirm that the AC wall plug power adapter is the charger provided with MP500. If the input does not comply with the requirements located in the general specifications section, the low watt range 0 % to 10 % may be displayed on the LCD.
- 3) If the device cannot be charged immediately after it is discharged, please wait for an hour and try again, it may enter the over-temperature protection.

In the event that the unit catches fire:

Never attempt to extinguish a fire if it is unsafe to do so. Contact your local fire department. If it is safe to do so use an electronic safe fire extinguisher or fire blanket. Do not touch any hot or burnt components. Dispose of the unit only when safe to do so after the unit is extinguished and fully cooled.

Getting the Battery Pack Wet.

Warning: Getting your battery pack wet could cause electric shock or other bodily harm. Never attempt to power on a wet battery pack.

Surface Water: IF your battery pack was lightly splashed with water, wipe the unit dry and allow it to fully dry For several hours before powering on.

Water got inside: IF water entered the battery pack, do not touch the battery pack and place it in a safe area until Fully dry. Do not attempt to power the battery pack on and dispose of the battery pack in accordance with local laws.

Battery fell into water:

Do not attempt to retrieve the battery back, and contact your local fire department for guidance. If unit is retrieved from the water, do not touch the battery pack and place it in a safe area until fully dry and dispose of it properly in accordance with proper battery disposal.



CLEANING

•Only clean the surface of the unit using a dry, non-abrasive cloth. You can use cleaners designed for mobile phones or computer screens. To ensure adequate cooling, vacuum the fan vents to remove dust and debris.

TRANSPORTATION AND STORAGE

- Battery life may be reduced if not used for an extended period of time. Discharge the Power Station to 30% battery life, then charge to 85% every 3 month to prolong battery life.
- DO NOT place the product near a heat source, such as a car in direct sunlight, a fire source, or a heating stove.
- Store the product in a dry environment. DO NOT place the product where it may contact water or high humidity.
- Make sure no small metal objects can fall on or around the product while in storage.
- Never transport a product with a battery power level higher than 30%.
- Never store the product in environments below -4°F (-20°C) or above 113°F (45°C).

RECYCLING



Dispose of the unit in hazardous material-specific recycling locations only after a complete discharge (if possible). Batteries are hazardous chemicals. Strictly follow your local regulations regarding battery disposal and recycling. Dispose of the unit immediately if it cannot be powered on after over-discharging.

Always return your used electronic products, batteries, and packaging materials to dedicated collection points to prevent uncontrolled waste disposal and promote the recycling of materials.

DISCLAIMERS

All information, illustrations, and specifications in this manual were in effect at the time of publishing. The illustrations used in this manual are intended as representative reference views only. We reserve the right to make any specification or design change without notice.

ALL RIGHTS RESERVED

All rights reserved. No reproduction allowed in any form without written permission from Wattbricks

FCC STATEMENT

This device complies with Part 15 of the FCC Rules. Operation is subject to the following two conditions:

(1) This device may not cause harmful interference, and (2) This device must accept any interference received, including interference that may cause undesired operation.

NOTICE

Transportation: The power station meets all legal requirements for the transportation of dangerous goods. The capacity of the lithium battery pack exceeds 100Wh. According to international standards Standard, if the power station is transported by air, it must be transported in accordance with IATA standard packaging. The instructions and labeling requirements of the International Air Transport Association and related declarations must be completed.



Not permitted on aircrafts



Avoid dropping



To preserve the battery lifespans, please use and recharge at least once every 3 months



Do not disassemble



Use original or certified charger and cables



It's not waterproof,do not expose to liquids



Avoid extreme temperature



Please dispose of batteries and electronic goods in accordance with local regulations

ACCESSORY LIST

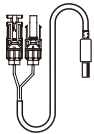

MC4-7909
connector cable

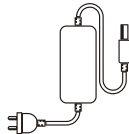

AC 100-240V wall plug
power adapter

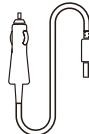

12V Car Charger
cable



User Manual

Recommend to use 120W Solar panel (not included).

LIMITED WARRANTY

1. DURATION : One (1) year from the date of purchase by the original purchaser (retail customer) on products used solely for consumer applications; if a product is used for business, commercial, or industrial applications, the warranty period will be limited to ninety (90) days from the date of purchase.
 2. WHO GIVES THIS WARRANTY (WARRANTOR):
CHONGQING DINKING POWER MACHINERY CO., LTD
 3. WHO RECEIVES THIS WARRANTY(PURCHASER):
The original purchaser (other than for purposes of resale) of the Genmax' s inverter.
 4. WHAT PRODUCTS ARE COVERED BY THIS WARRANTY:
Any portable generator supplied or manufactured by Warrantor.
 5. WHAT IS COVERED UNDER THIS WARRANTY:
Substantial defects on material and workmanship which occur within the duration of the warranty period.
 6. WHAT IS NOT COVERED UNDER THIS WARRANTY:
 - A. Transportation charges for sending the product to Warrantor or its authorized service representative for warranty service, or for shipping repaired or replacement products back to the customer; these charges must be borne by the customer.
 - B. Damages caused by abuse, accident, shipping, misuse, overloading, modification, and the effects of corrosion, erosion and normal wear and tear.
 - C. Warranty is voided if the customer fails to install, maintain and operate the product in accordance with the instructions and recommendations set forth in the owner's manual(s), or if the product is used as rental equipment.
 - D. Pre-delivery service, i.e. assembly, oil or lubricants, and adjustment.
 - E. Items or service that are normally required to maintain the product, i.e. lubricants and filters.
 - F. Warrantor will not pay for repairs or adjustments to the product, or for any costs or labour, performed without Warrantor's prior authorization.EXCLUSIONS AND LIMITATIONS : Warrantor makes no other warranty of any kind, express or implied. Implied warranties, including warranties of merchantability and of fitness for a particular purpose, are hereby disclaimed. This warranty service described above is the exclusive remedy under this warranty; liability for incidental and consequential damages is excluded to the extent permitted by law.
 7. RESPONSIBILITIES OF PURCHASER UNDER THIS WARRANTY:
 - A. The purchaser must provide dated proof of purchase and must notify Warrantor within the warranty period.
 - B. Deliver or ship the serviced generator or component to the nearest Warrantor's authorized service representative. Freight costs, if any, must be borne by the purchaser.
 8. HAVE QUESTIONS?
Email: warrantlessmallengines@gmail.com Phone: 866-960-2920
-

WARRANTY CARD

PERSONAL INFORMATION

Name: _____
Street Address: _____
City, State, ZIP: _____
Country: _____
Phone Number: _____
E-Mail: _____

INVERTER INFORMATION

Model Number: _____
Serial Number: _____
Date Purchased: _____
Purchased From: _____



GENMAX[®]